

Disassembly diagram

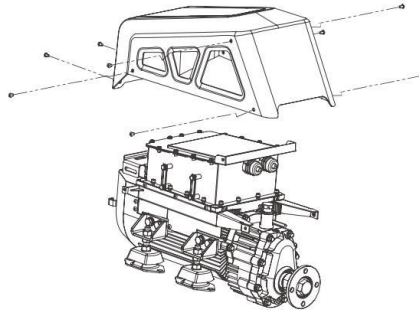

Step 1

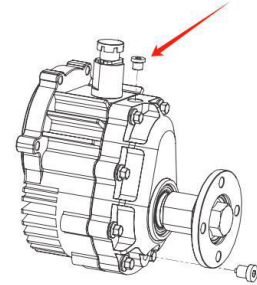

Step 2

I10 add Gear oil

STEP:

1. Remove 8 hexagon bolts (3 on the left and right sides and 2 on the back side of the air-cooled module) of the cover with 3mm hex wrench, and remove the cover.
2. Pour 220ml lubricating oil (brand: Liqui moly Top Tec ATF 1900) into the gear box through the mounting hole of the oil bolt, check that the rubber ring of the oil bolt is not damaged (if there is, the oil bolt needs to be replaced), install and tighten the oil bolt;
3. Detect whether there is oil leakage;
4. install the cover.