

Smart Display 5" User Manual



Acknowledgement

Thanks for choosing ePropulsion products, your trust and support in our company are sincerely appreciated. We are dedicated to providing high-performance electric outboards, electric outboards, sup/kayak motors, reliable lithium batteries and accessories.

Welcome to visit www.epropulsion.com and contact us if you have any concerns.

Using This Manual

Before use of the product, please read this user manual thoroughly to understand the correct and safe operations. By using this product, you hereby agree that you have fully read and understood all contents of this manual. ePropulsion accepts no liability for any damage or injury caused by operations that contradict this manual.

Due to ongoing optimization of our products, ePropulsion reserves the rights of constantly adjusting the contents described in the manual. ePropulsion also reserves the intellectual property rights and industrial property rights including copyrights, patents, logos and designs, etc.

This manual is subject to update without prior notice, please visit our website www.epropulsion.com for the latest version. If you find any discrepancy between your products and this manual, or should you have any doubts concerning the product or the manual, please visit www.epropulsion.com.

ePropulsion reserves the rights of final interpretation of this manual.

This manual is multilingual, in case of any discrepancy in the interpretation of different language versions, the English version shall prevail.

Symbols

The following symbols will help to acquire some key information.

 Important instructions or warnings

 Useful information or tips

Product Identification

The picture below indicates the serial numbers of Smart Display 5". Please note the position of the serial numbers and record them for access to warranty service and other after-sale services.

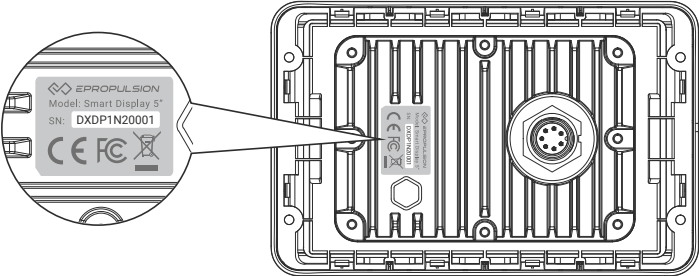
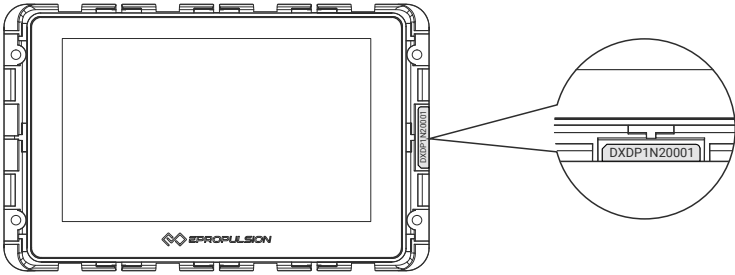

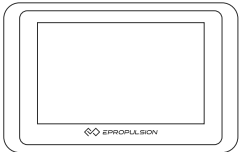
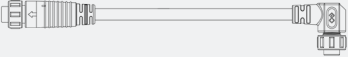

Table of Contents ---

- Acknowledgement** 1
- Using This Manual** 1
- Symbols**..... 1
- Product Identification**..... 2
- 1 Product Overview**..... 4
 - 1.1 In the Package 4
 - 1.2 Specifications 4
 - 1.3 Important Notes 5
 - 1.4 Declaration of Conformity 5
- 2 Preparations**..... 7
- 3 Function Description**..... 9
- 4 Warranty**..... 10
 - 4.1 Out of Warranty 11
 - 4.2 Limited Warranty Claim Procedures 12

1 Product Overview

ePropulsion Smart Display 5" is connected to the motor system by wire, displaying power, speed, battery level, etc., system information and setting the system function.

1.1 In the Package

Items	Qty./Unit	Figure
Smart display 5"	1	
Communication cable	1	
User manual, fixing guide	1 Set	
screws	4 pcs	

1.2 Specifications

Weight	Resolution	Communication	Communication distance	Dimensions
600g	800x480	Wired	≤15m	158 ×104 ×62mm

 Other accessories are not included in the package. Users can buy official accessories provided by ePropulsion from ePropulsion authorized dealers.

 Save ePropulsion original package for transport and storage.

1.3 Important Notes

1. Only adults who have fully read and understood this manual are allowed to operate this product.
2. Check the function of the Smart display 5" before use.
3. Make sure the Smart display 5" is properly installed before use.
4. When the Smart display 5" is not in use, please use the protective cover to protect it.
5. Please keep away from sharp objects to avoid scratching the display.

1.4 Declaration of Conformity

Object of the Declaration:

Product: Smart Display 5"

Model: Smart Display 5"



We Guangdong ePropulsion Technology Co., Ltd., hereby, declares that this equipment is in compliance with the applicable Directives and European Norms, and amendments. The full text of the EU declaration of conformity is available at the following internet address: <http://yachter123.com/sy>

The object of the declaration is in conformity with the following directives:

Electromagnetic Compatibility (EMC) Directive 2014/30/EU

Applied Standards:

EN61000-6-2: 2005

EN61000-6-3: 2007+A1:2011

This device complies with part 15 of the FCC Rules: Operation is subject to the following two conditions:

1. This device may not cause harmful interference and,
2. This device must accept any interference received, including interference that may cause undesired operation.

Manufacturer

Name: Guangdong ePropulsion Technology Limited

Address: Room 801, Building 1, 11 Daxue Road, Songshan Lake, Dongguan, Guangdong Province, China

Signature: 陶师正

Date: 2nd of June, 2023

Shizheng Tao, Chief Executive Officer & Cofounder of
Guangdong ePropulsion Technology Limited

2 Preparations

Please follow the step below to fix the Smart Display 5" on the console.

- ① In the position reserved for the display on the console, find the screw positions referring to the fixing guide and drill holes with a 2.5mm drill bit.

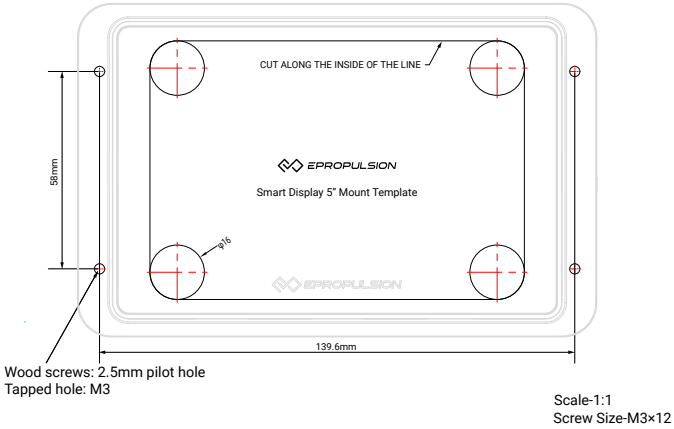

- ② Peel off the display trim from the four corners.

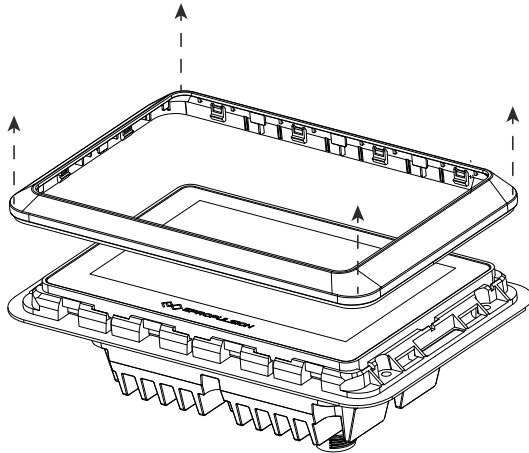

- ③ Align the display with the four holes that have been drilled, pay attention to the installation direction, and judge the direction according to the EPROPULSION logo. Install the display and tighten the screws.

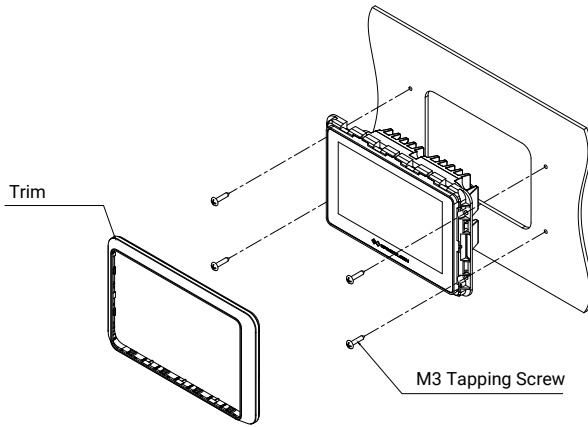

- ④ Put the display trim back on the display and press it in place of the four corners so that the trim is flush with the display.

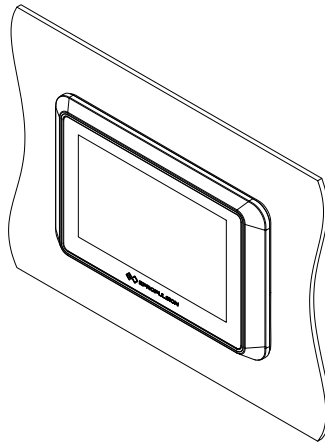

3 Function Description ---



Please read the user manual of the motor.

4 Warranty

Guangdong ePropulsion Technology Co., Ltd. (“ePropulsion”), China, warrants its products to be free of defects in material and workmanship under normal usage with proper installation and routine maintenance for a period of twenty-four (24) months from date of delivery of products to end customers (the “Limited Warranty Period”). The Limited Warranty is provided to the first end customer of ePropulsion products ONLY. The Customer is entitled to free repair or replacement of defective or non-conform parts. Any warranty claim must be made within six (6) months of discovery of issues as provided below.

If the Limited Warranty Period expires, you can still enjoy maintenance services from dealers/distributors authorized by ePropulsion (the “ePropulsion Service Partners”) with minimum maintenance charge per occurrence.

In all warranty cases, ePropulsion will only bear the repair cost and other costs (such as those related to product installation, disassemble, transportation, financing, rental, etc.) as a direct result for issues covered by the Limited Warranty only. Any costs irrelevant to or out of the scope of the Limited Warranty will be born by the Customer alone., which shall NOT include costs irrelevant such as those related to product installation, disassemble, transportation, financing, rental, etc.

Beyond the Limited Warranty, the Customer may have statutory rights in your jurisdiction according to applicable laws. Nothing in this Limited Warranty affects such rights. The Customer may have warranty claim rights arising from the purchase contract with ePropulsion Service Partners in addition to the rights granted by this Limited Warranty.

Products for commercial/professional use, even if only temporarily, are not covered by the Limited Warranty. Instead, the statutory warranty in your jurisdiction shall apply. You are encouraged to consult with ePropulsion Service Partners for applicable warranty and advice before engaging in such use.

*** Commercial/professional Use refers to application cases that have high use frequency, high-reliability requirement or aim for money making, etc.**

To keep your warranty valid, you shall follow:



Keep the product label intact and record the Serial Number shown on the label. Never tear the label off the product. A product without the original product label is not covered by the Limited Warranty provided by ePropulsion;



The Limited Warranty is not transferable and will not be reissued;



The Limited Warranty may change from time to time. Pls visit our website (<http://www.epropulsion.com>) for the latest version.

4.1 Out of Warranty

ePropulsion may refuse a warranty claim if:

- Any improper operation contradicts what is written in the user manual;
- Accident, misuse, dropping, improper care or storage, willful abuse, physical damage, overcharging, over discharging, or unauthorized repair;
- Water ingress caused by external sources such as fishing nets, submerging underwater, etc;
- Product modification, alternation, disassembly, or parts/accessories attachment, which are not expressly permitted or recommended by ePropulsion;
- Failure of, or damage caused by, any 3rd party products;
- Consumables are out of warranty scope (like propeller, anode...etc.);
- Purchases of product from unauthorized dealers or seller;
- Normal wear and tear and routine servicing are excluded from the warranty;
- The product gets further damaged due to improper packing during delivery. The further damaged part will be deemed as out of warranty coverage;
- Lithium battery is classified as a UN9 hazardous item, posting and packing must be in accordance with the relevant law of the local country directive. Non-compliance may result in out of warranty coverage.

4.2 Limited Warranty Claim Procedures

The Customer shall follow the warranty claim process to make a Limited Warranty claim:

1. Contact your nearest ePropulsion Service Partners and they will provide further instruction to you if such defects are covered by the Limited Warranty or theirs.
2. Send the defective product to them together with Proof of 1(st)-time Purchase (e.g., receipt, invoice, etc., with information of product purchased and date of purchase), the Confirmation of Online Warranty Registration, ex-factory Serial Number, etc. Note that all labels shall be kept intact. The warranty is valid only when the information above is correct, genuine, and complete;
3. Make sure the product is properly packed during delivery, the original package is highly recommended.
4. The ePropulsion Service Partners will conduct diagnosis and examination on the defective products to check the validity of the warranty claim.
5. If your warranty claim is accepted, the Product or its defective components/parts will be either repaired or replaced free of charge. Note that any delivery cost incurred in the process shall be bearded by you.
6. In case your warranty claim be rejected, a repair/replace cost and fee with round trip delivery cost will be estimated and sent to you for confirmation. ePropulsion Service Partners will only begin the work after your written confirmation.

Thanks for reading this user manual.

If you have any concerns or find any problems while reading, please don't hesitate to contact us.

We are delighted to offer service for you.

WARRANTY CARD || ePropulsion Control System

(*In order to validate warranty, please fill in this form first and read the Warranty Policies.)

|| OWNER INFO. ||

Owner Name			
Address			
Phone		Email	

|| DEALER INFO. ||

Store Name			
Address			
Phone		Email	

|| PRODUCT INFO. ||

Date of Purchase (mm/dd/yyyy)	
Serial No.	

Guangdong ePropulsion Technology Limited

Webseite: www.epropulsion.com

E-Mail: service@epropulsion.com