



## **NAVY Evo User Manual**

### **Navy Evo Bedienungsanleitung**

2021.12 Version 1.2

Copyright © 2021 ePropulsion. All Rights Reserved



## Acknowledgement

---

Thanks for choosing ePropulsion products, your trust and support in our company are sincerely appreciated. We are dedicated to providing high-performance electric outboards, electric outboards, sup/kayak motors, reliable lithium batteries and accessories.

Welcome to visit [www.epropulsion.com](http://www.epropulsion.com) and contact us if you have any concerns.

## Using This Manual

---

Before use of the product, please read this user manual thoroughly to understand the correct and safe operations. By using this product, you hereby agree that you have fully read and understood all contents of this manual. ePropulsion accepts no liability for any damage or injury caused by operations that contradict this manual.

Due to ongoing optimization of our products, ePropulsion reserves the rights of constantly adjusting the contents described in the manual. ePropulsion also reserves the intellectual property rights and industrial property rights including copyrights, patents, logos and designs, etc.

This manual is subject to update without prior notice, please visit our website [www.epropulsion.com](http://www.epropulsion.com) for the latest version. If you find any discrepancy between your products and this manual, or should you have any doubts concerning the product or the manual, please visit [www.epropulsion.com](http://www.epropulsion.com).

ePropulsion reserves the rights of final interpretation of this manual.

This manual is multilingual, in case of any discrepancy in the interpretation of different language versions, the English version shall prevail.

## Symbols

---

The following symbols will help to acquire some key information.



Important instructions or warnings



Useful information or tips

# Product Identification

---

Below picture indicates the serial numbers of NAVY Evo. Please note the position of the serial numbers and record them for access to warranty service and other after-sale services.

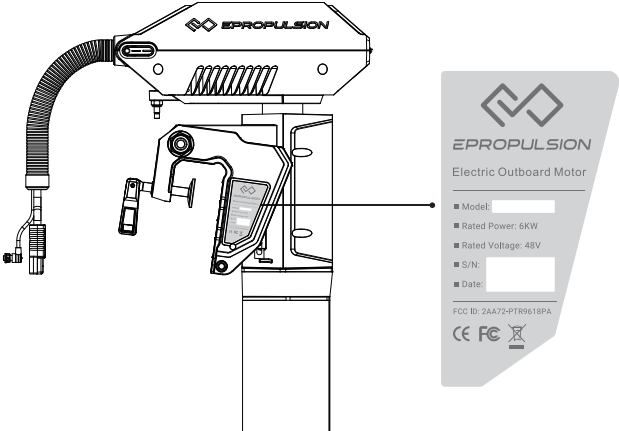

Figure 0-1

# Table of Contents

---

<b>Acknowledgement</b> .....	<b>1</b>
<b>Using This Manual</b> .....	<b>1</b>
<b>Symbols</b> .....	<b>1</b>
<b>Product Identification</b> .....	<b>2</b>
<b>1 Product Overview</b> .....	<b>6</b>
1.1 In the Package .....	6
1.2 Parts and Diagram.....	8
1.3 Specifications .....	9
1.4 Important Notes .....	10
1.5 Declaration of Conformity.....	11
<b>2 Preparations</b> .....	<b>12</b>
2.1 Selecting the Battery .....	12
2.2 Selecting and Mounting the Propeller.....	13
<b>3 Mounting the Outboard Motor</b> .....	<b>15</b>
3.1 Position of Mounting.....	15
3.2 Mounting the Outboard.....	16
3.3 Mounting the Steering System .....	17
3.4 Mounting the Evo Tiller .....	17
<b>4 Connecting the Battery</b> .....	<b>19</b>
4.1 Connecting a 48V Battery .....	19
4.2 Connecting E Series Batteries .....	20
4.3 Batteries in Series/Parallel .....	22
<b>5 Evo Remote Control/Evo Tiller</b> .....	<b>23</b>
5.1 Display Panel .....	23
5.2 Charging the Evo Remote Control .....	28
5.2.1 Charging by Solar Power .....	28
5.2.2 Charging by Wired Connection .....	28
5.3 Power Adjusting .....	30
5.3.1 Power Adjusting for Evo Control System .....	30
5.3.2 Recalibration .....	31

5.4 Use of Kill Switch.....	32
5.5 Use of Safety Wristband .....	33
5.5.1 Pairing Safety Wristband with Evo Control System .....	33
5.5.2 Man Overboard Protection .....	33
5.5.3 Emergency Stop.....	33
5.6 Pairing Evo Control System with the Outboard .....	34
5.7 Hydro Generation Function .....	36
5.8 Warning Messages.....	37
<b>6 Configurations.....</b>	<b>39</b>
6.1 Preference Settings.....	39
6.2 Battery Configuration .....	39
<b>7 Checklist before Use.....</b>	<b>42</b>
<b>8 Starting the Outboard .....</b>	<b>42</b>
<b>9 Stopping the Outboard.....</b>	<b>43</b>
<b>10 Trim Angle Adjusting .....</b>	<b>44</b>
<b>11 Anti-grounding Mode.....</b>	<b>46</b>
<b>12 Thread the communication cable into the bellow .....</b>	<b>47</b>
<b>13 Maintenance.....</b>	<b>49</b>
13.1 Notes.....	49
13.2 Maintenance Time Table .....	49
13.3 Propeller Maintenance.....	50
13.4 Replacing the Anode .....	50
13.5 Maintenance of Electrical Contacts.....	51
<b>14 Transportation and Storage .....</b>	<b>52</b>
14.1 Transport.....	52
14.2 Placement.....	52
14.3 Storage.....	52
<b>15 Emergency Situations .....</b>	<b>53</b>
15.1 Collision .....	53
15.2 Sudden Outboard .....	53
15.3 Low Battery Level.....	53
15.4 Over-temperature Protection .....	53

<b>16 Warranty .....</b>	<b>54</b>
16.1 Warranty Policies.....	54
16.2 Out of Warranty .....	55
16.3 Warranty Claim Procedures.....	55

# 1 Product Overview

NAVY 6.0 Evo is a 6kW electric outboard motor, and NAVY 3.0 Evo is a 3kW electric outboard motor.



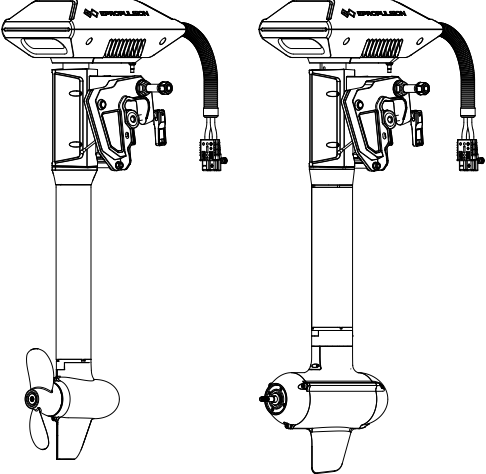

 Evo control system is necessary when operating the outboard motor, but it is not included in the NAVY Evo. It need be purchased separately by users from ePropulsion authorized dealers.

## 1.1 In the Package

Unpack the package and check if there is any damage caused during transport. Check all the items inside the package against the below list. If there is any transport damage or lack of any listed item, please contact your dealer immediately.

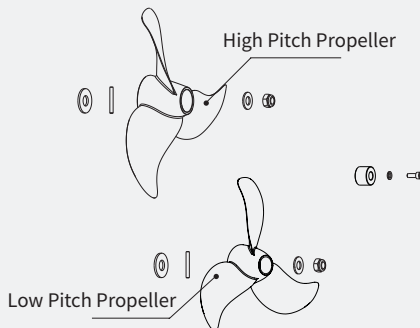
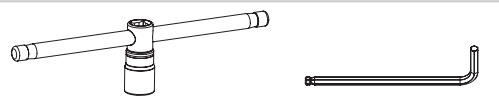
Items	Qty./Unit	Figure
Outboard (Main part)	1 set	 <p data-bbox="490 1122 634 1146">NAVY 3.0 Evo</p> <p data-bbox="752 1122 896 1146">NAVY 6.0 Evo</p>

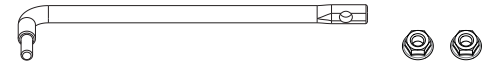

Items	Qty./Unit	Figure
Propeller Assy. (delivered with NAVY 6.0 Evo)	2 Sets	 <p>High Pitch Propeller</p> <p>Low Pitch Propeller</p>
Wrench Set	1 Set	 <p>19mm Wrench</p> <p>M6 Wrench</p>
Main Switch Cable	1 Set	
Link Arm	1 Set	
Tiller Shaft Lanyard Evo	1 Piece	
User Manual, Warranty Card, Quality Certificate & Invitation Card	1 Set	 <p>Warranty</p> <p>User Manual</p> <p>Quality Certificate</p> <p>Invitation Card</p>



Other accessories not included in the package are also required to operate the outboard motor, such as Evo control system, battery, charger and communication cable, etc. Users can buy official accessories provided by ePropulsion such as Evo Remote Control, Evo Tiller, E Series Battery, E battery Charger and communication cable, etc. from ePropulsion authorized dealers.

💡 Note that the propeller of NAVY 3.0 Evo is attached on the motor before delivery and the two propellers of NAVY 6.0 Evo in the package differ in specifications: the high-pitch propeller (Diameter: 320mm/12.6inch, Pitch: 10.8inch) and the low-pitch propeller (Diameter: 340mm/13.4inch, Pitch: 8.5inch). They share the accessories.

💡 Save ePropulsion original package for transport and storage.

## 1.2 Parts and Diagram

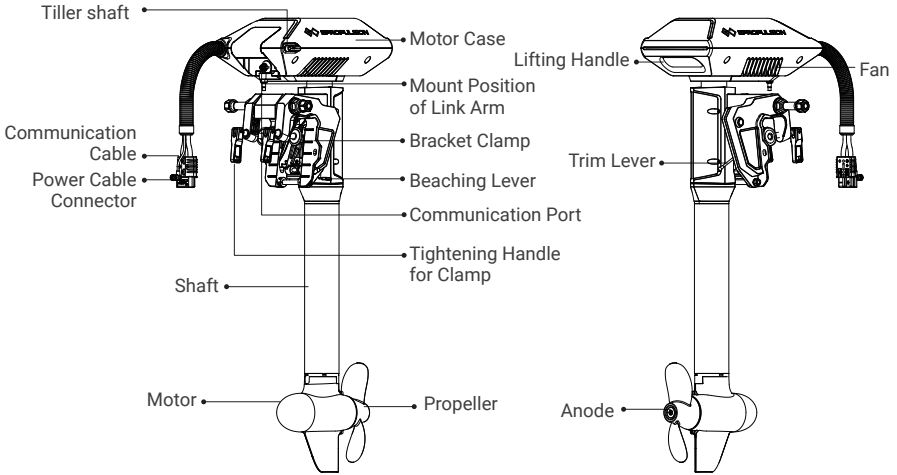

Figure 1-1 NAVY 3.0 Evo

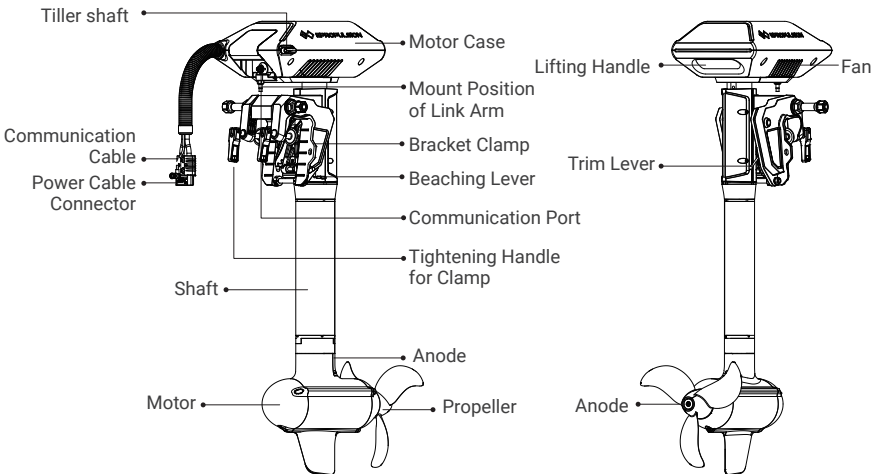

Figure 1-2 NAVY 6.0 Evo

## 1.3 Specifications

	NAVY 3.0 Evo-S/L	NAVY 6.0 Evo-S/L
Type	Electric Outboard Motor	
Input Power	3 kW	6 kW
Rated Voltage	48 V	
Input Voltage	39 V ~ 60 V DC	39 V ~ 60 V DC
Equivalent Power	6 hp	9.9 hp
Max Overall Efficiency	51%	57%
Rated Rotation Speed	2300 rpm	1500 rpm
Control System	Evo Remote Control / Evo Tiller / Evo Side Mount Control / Evo Dual Remote Control	
Dimension (L×W×H)	S: 437 × 314 × 1049 mm / 17.2 × 10.7 × 41.3 inches L: 437 × 314 × 1174 mm / 17.2 × 10.7 × 46.2 inches	S: 547 × 314 × 1087 mm / 21.5 × 10.7 × 42.8 inches L: 547 × 314 × 1212 mm / 21.5 × 10.7 × 47.7 inches
Shaft Length	S: 634 mm / 25 inches L: 759 mm / 29.9 inches	
Weight	24.3 kg(S)/25.1 kg(L)	36 kg (S) / 36.8 kg (L)
Trim Angles	Manual, 0°, 5°, 10°, 15°	
Tilt Angle	Manual, 60°	
Propeller (Diameter × Pitch)	10.2" × 6.7" 2-blade composite propeller	12.6" × 10.8" 3-blade composite propeller 13.4" × 8.5" 3-blade composite propeller 12.6" × 8.7" 3-blade aluminum propeller (Optional)
Recommended Operating Ambient Temperature	-10°C to 45°C 14°F to 113°F	

## 1.4 Important Notes

1. Check the status of the outboard and battery level before each trip.
2. The distance and speed value displayed is measured by Global Positioning System (GPS), there may exist small errors due to GPS signal strength degradation or some external environment conditions like currents, winds and change of course.
3. Ensure the top of outboard is uncovered to avoid GPS signal attenuation.
4. Familiarize yourself with all the outboard operations, including starting, steering, stopping, trim adjusting and tilting.
5. Only adults who have fully read and understood this manual are allowed to operate this product.
6. Follow the boat manufacturer's instructions to choose a suitable outboard. Do not overload neither the boat nor the outboard.
7. Stop the outboard immediately if someone falls overboard during the trip.
8. Protect the battery from dropping into water or short-circuiting.
9. Follow the battery manufacturer's instructions and pay attention to short circuit, over-heat, over-charge and over-discharge.
10. Operate the outboard only when the propeller is underwater.
11. Tilt up the outboard motor above water after use.
12. Wash the outboard in time with fresh water after sailing in salt water.
13. Clean all electronic contacts with contact spray about every two months.
14. Do not leave the outboard in water if the boat speed reaches 30km/h which is driven by other power such as sailing or rowing.
15. An error code will display on the panel if the outboard malfunctions. Put the throttle to zero position and turn off the main switch, then refer to *Chapter 5.8 Warning Messages* for details and solutions.
16. For safety consideration, the system will shut down automatically when the temperature of the motor or driver rise too high or the battery voltage drops too low during operation.
17. Users are responsible to assemble the propeller and steering wheel. If other assembly or disassembly is required, please contact your dealer. ePropulsion accepts no liability for any damage or malfunction caused by operations that violate this manual.
18. If the communication cable is not connected, ensure to cover the cap of the communication connector on the machine, otherwise the connector will corrode and the machine will not be able to communicate.

## 1.5 Declaration of Conformity

### Object of the Declaration:

Product: Electric Outboard

Model: NAVY 6.0 Evo, NAVY 6.0 Evo-L, NAVY 6.0 Evo-S, NAVY 6.0 Evo-C, NAVY 3.0 Evo, NAVY 3.0 Evo-L, NAVY 3.0 Evo-S, NAVY 3.0 Evo-C

**Company Name:** Guangdong ePropulsion Technology Limited

**Address:** Room 201, Bldg.17A, 4th XinZhu Road, SongShan Lake District, Dongguan City, Guangdong Province, China

The object of the declaration is in conformity with the following directives:

EMC-directive	2014/30/EU
MD-directive	2006/42/EC
RED-directive	2014/53/EU

### Applied Standards:

EN 55014-1:2017	EN 300328:2019
EN 55014-2:2015	EN 50663:2017
EN 61000-3-2:2014	EN 62368-1:2014+A1:2017
EN 61000-3-3:2013/A1:2019	EN 60204-1:2018
EN 301489-1:2019	EN ISO 12100:2010
EN 301489-3:2019	

This device complies with part 15 of the FCC Rules: Operation is subject to the following two conditions:

1. This device may not cause harmful interference and,
2. This device must accept any interference received, including interference that may cause undesired operation.

Signature: 

Shizheng Tao, Chief Executive Officer & Cofounder of  
Guangdong ePropulsion Technology Limited

## 2 Preparations

---

### 2.1 Selecting the Battery



It is recommended to use ePropulsion E Series Batteries.

Lithium-based and lead-acid batteries can be used to supply power for NAVY Evo. Considering the high performance in energy density and discharge ability, lithium-based batteries are more preferable. To ensure that NAVY Evo can work at its full power continually, the batteries are required to possess over 62.5A(NAVY 3.0 Evo) or 125A(NAVY 6.0 Evo) of continuous discharge current. To ensure at least one hour of duration, the battery capacity should reach 3000Wh(NAVY 3.0 Evo) or 6000Wh(NAVY 6.0 Evo) or above.

The rated continuous discharge current is affected by the battery type and quantity of parallel batteries. To use lead-acid batteries, conventional lead-acid or AGM or GEL batteries are acceptable, while starter batteries are not recommended. Traction batteries or deep cycle batteries are more preferable as they give power over sustained period of time. Besides, the deep cycle marine batteries are also capable.

Battery capacity is a major factor that affects trip duration and distance. For instance, a battery with 48V of rated voltage completely discharges at a continuous current of 125A in 1 hour, so its rated capacity is 6000Wh ( $125\text{Ah} \times 48\text{V} = 6000\text{Wh}$ ), we also can say its rated capacity is 125Ah. The maximum power of NAVY 6.0 is 6kW which means the system can be running at full power for about 1 hour when using this battery. You can select a battery with proper capacity based on your requirements for travelling time and distance. Note that the operating time and distance are also affected by the input power of the outboard plus the external environment and temperature. In addition, boat type and load also play important roles.

Users can connect four 12V batteries in series to make a 48V battery set and use it to supply power for NAVY 6.0. Users can also enlarge the battery capacity by parallel configuration.



When using E Series Batteries, the batteries will work well once being correctly connected. When using non-ePropulsion batteries, before starting the outboard, users should configure the batteries via the Evo Control System for the first time use, otherwise the batteries may not work properly.

**⚠** Only use the same batteries (same model, same capacity, same age and same manufacturer) in series or in parallel configuration. Variations in the batteries will cause damage to them.

## 2.2 Selecting and Mounting the Propeller

For NAVY 3.0 Evo, the propeller of NAVY 3.0 Evo is attached on the motor before delivery. If necessary to replace a propeller, please follow the steps below to replace and mount the propeller.

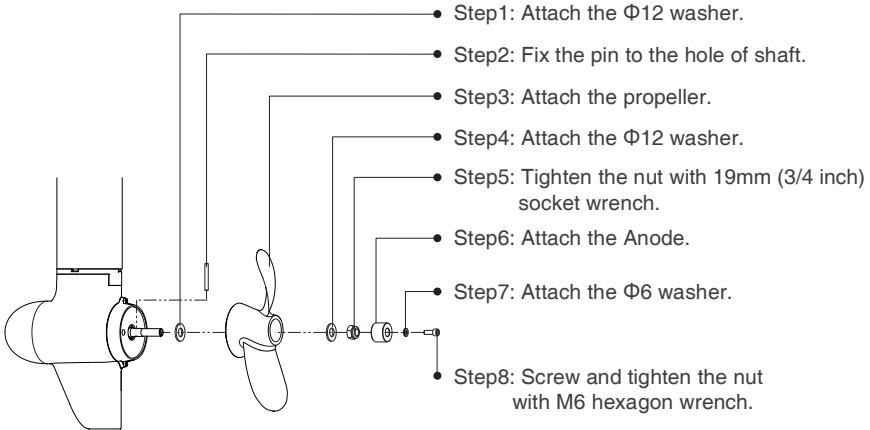

Figure 2-1

For NAVY 6.0 Evo, there are two types of propellers are available. Users can select a proper propeller based on different conditions. For a heavily loaded boat with large thrust, a low pitch propeller is more appropriate. Inversely, for a lightly loaded boat with a fast running speed, a high pitch one is preferable.

In the delivery package, there are two sets of propellers, including a low-pitch propeller and a high-pitch propeller. The low-pitch propeller with a larger diameter generates larger thrust at low speed, while the high-pitch propeller generates proper thrust to propel boats at high speed. It is recommended to use the high-pitch propeller if the boat speed can reach 15km/h or above, as the propeller can't work at full performance at low speed. Figure 2-1 displays how to mount a propeller correctly.

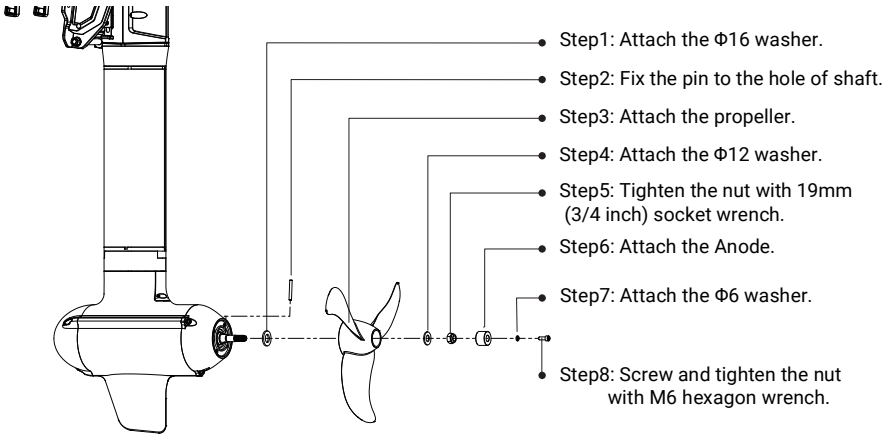

Figure 2-2



## 3 Mounting the Outboard Motor

Select an outboard with proper shaft length according to the transom height of your boat. The top of the propeller should be 100mm to 150mm below the water.

The outboard should be mounted on the centerline of your boat. If the boat shape is asymmetric, please consult your dealer for proper solution.

### 3.1 Position of Mounting

The mounting height of the outboard affects the running speed seriously. When the mounting height is too high, cavitation may occur, which may lead to speed slow-down, energy waste, and propeller damage. When the mounting height is too low, the water resistance will reduce both travelling speed and performance of the outboard.

In general, the optimal mounting height is affected by the specific conditions of a boat. In order to get the optimal mounting height, it's suggested to test running by mounting the outboard at different heights. Please consult your dealer for more help.

Transom Height	Recommended Model
Higher than 500mm	NAVY 3.0 Evo-L / NAVY 6.0 Evo-L
400mm~500mm	NAVY 3.0 Evo-S / NAVY 6.0 Evo-S

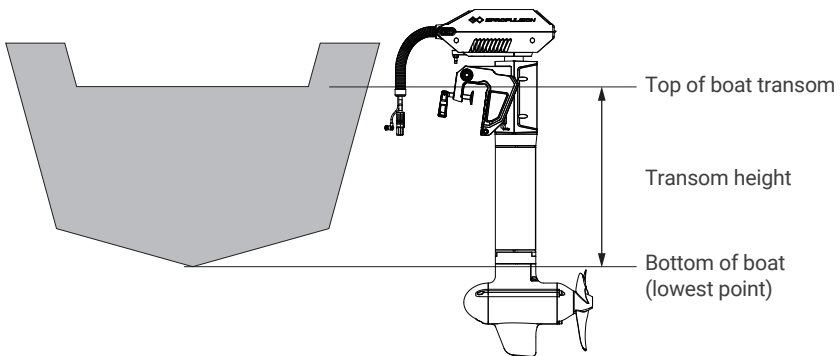

Figure 3-1 NAVY 6.0 Evo

## 3.2 Mounting the Outboard

### Method 1

Rotate the two clamps in clockwise direction to fix the outboard onto transom.

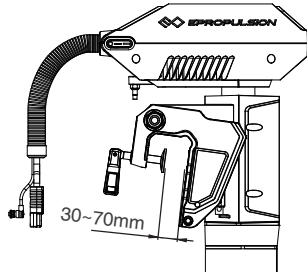

Figure 3-1

### Method 2

Use two screws to fix the outboard to the boat. The dimensions of the two mounting holes are shown below.

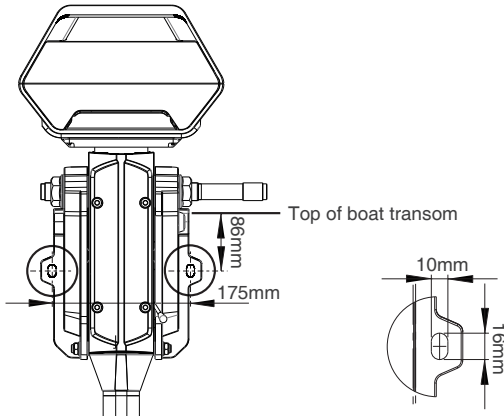



Figure 3-2

 Ensure the outboard is firmly fixed as loosened clamp screws may cause the outboard to fall into water or get damaged. Check the screws or clamps every time before use since they may be loosened because of mechanical vibrations.

 A cable is recommended to be used to avoid complete loss of your outboard in case it falls off the transom. Use the cable to connect your outboard and a secure mounting point on the boat.

### 3.3 Mounting the Steering System



Before using Evo Remote Control, please follow the fixing guide to fix the Evo Remote Control in the proper position.

When using the Evo Remote Control, please prepare a steering wheel (not supplied with NAVY Evo or the Evo Remote Control) and mount it on the corresponding position to control the direction.

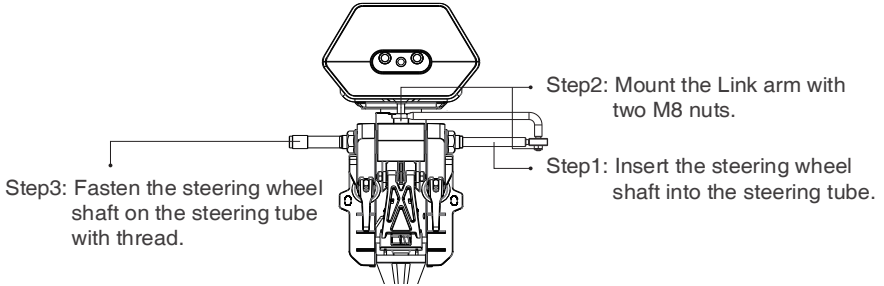

Figure 3-3

### 3.4 Mounting the Evo Tiller

1. Rotate the handle shaft counterclockwise, then pull out the handle shaft and decorative cover.

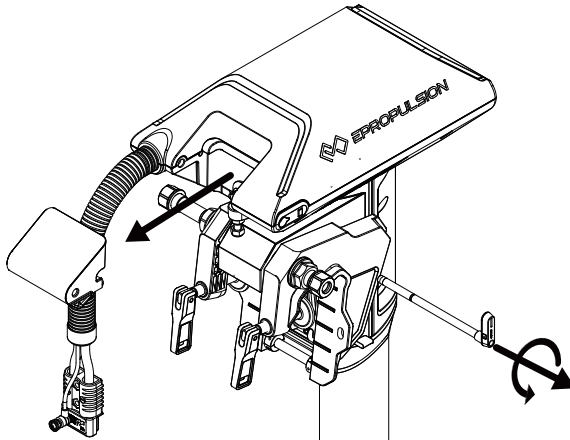

Figure 3-4

2. Install the tiller to the machine.

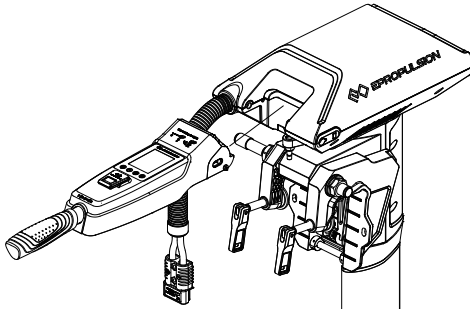

Figure 3-5

3. Insert the handle shaft into the hole to the end and lock it clockwise.

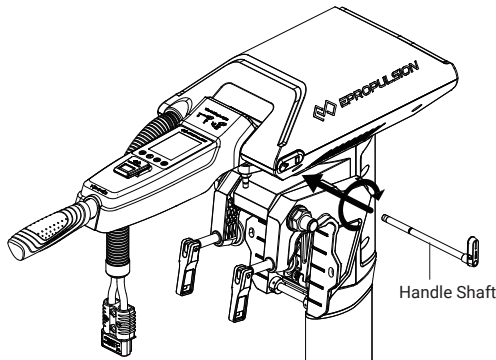

Figure 3-6

4. Connect the communication cable of Evo Tiller to the communication port of the NAVY Evo.

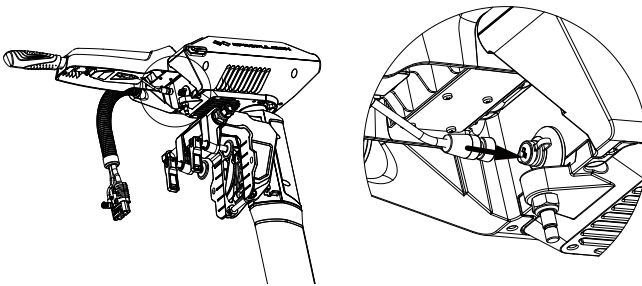

Figure 3-7

**⚠** Do not use the tiller handle to tilt or lift your outboard. The damage of tiller or battery base due to pushing down the handle is out of warranty.

## 4 Connecting the Battery

### 4.1 Connecting a 48V Battery

When using a battery, make sure the main switch is off before connection.

1. First connect the main switch cable to the battery.
2. Connect the main switch cables with the power cable from the outboard.

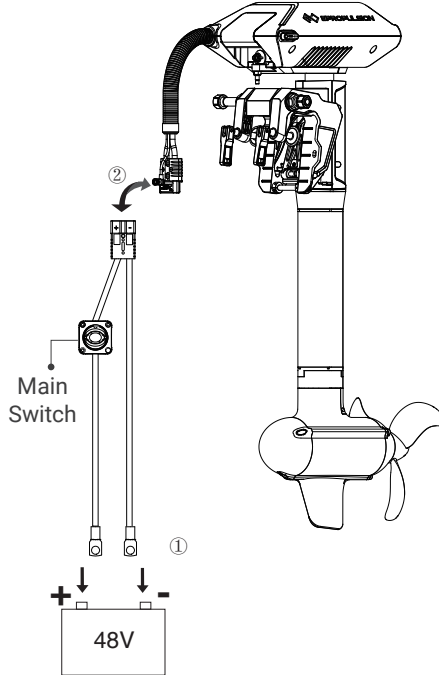







Figure 4-1

-  Avoid battery short-circuit during connection.
-  Do not short-circuit the main switch with other power supplies. The main switch should be mounted on the boat, and the back plate of the main switch should not be removed.
-  Outboard motor will stop working once the power cable disconnects.
-  Clockwisely rotate the main switch to power on the battery before use.
-  Users can also enlarge the battery capacity by connecting multiple batteries in parallel.

 The main switch and power cable are connected by the fixing screws that may loosen after long-time use. Loosen screws will lead to poor contact, which may result in overcurrent or other errors. If this problem is discovered, open the back cover of the switch, and tighten the screws inside.

## 4.2 Connecting E Series Batteries

When using E Series Batteries, make sure the main switch is off before connection.

1. First connect two batteries in parallel by a communication cable and two battery bridging cables.
2. Connect the main switch cable to the E Series Battery.
3. Connect the main switch cable with the power cable from the outboard.
4. Connect NAVY Evo outboard motor to the E Series Battery with a communication cable.

 It's recommended to connect the communication cable to obtain accurate battery information.

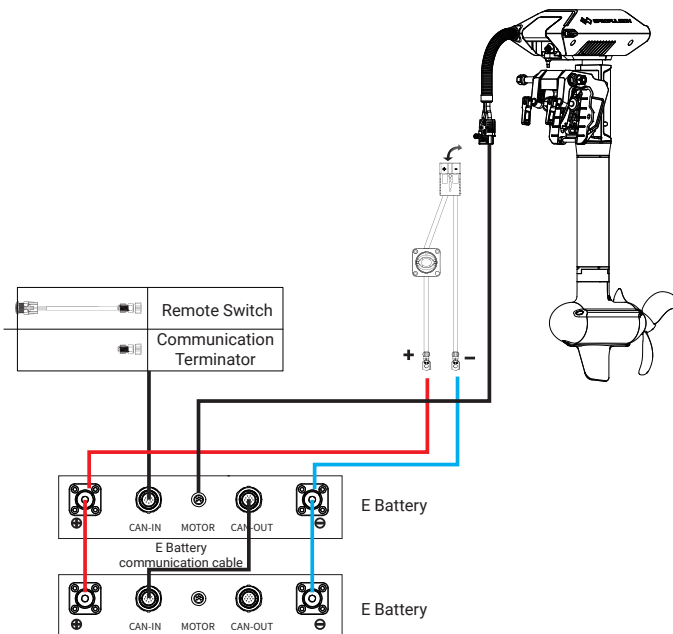









Figure 4-2

-  Avoid battery short-circuit during connection.
-  Do not short-circuit the main switch with other power supplies. The main switch should be mounted on the boat, and the back plate of the main switch should not be removed.
-  NAVY Evo outboard motor will stop once the power cable disconnects.
-  Use communication cables to connect E Series Batteries when multiple E Series Batteries are used in parallel.
-  Clockwisely rotate the main switch to power on the battery before use.
-  Users can also enlarge the battery capacity by connecting multiple batteries in parallel.
-  The main switch and the power cable are connected by the fixing screws that may loosen after long-time use. Loosen screws will lead to poor contact, which may result in overcurrent or other errors. If this problem is discovered, open the back cover of the switch, and tighten the screws inside.

### 4.3 Batteries in Series/Parallel

When connecting four 12V batteries in series to make a 48V battery set to supply power for NAVY Evo, use bridging cables to connect batteries in series (Figure 4-3). Make sure to connect the main switch cable to battery positive terminal and the other cable to battery negative terminal.

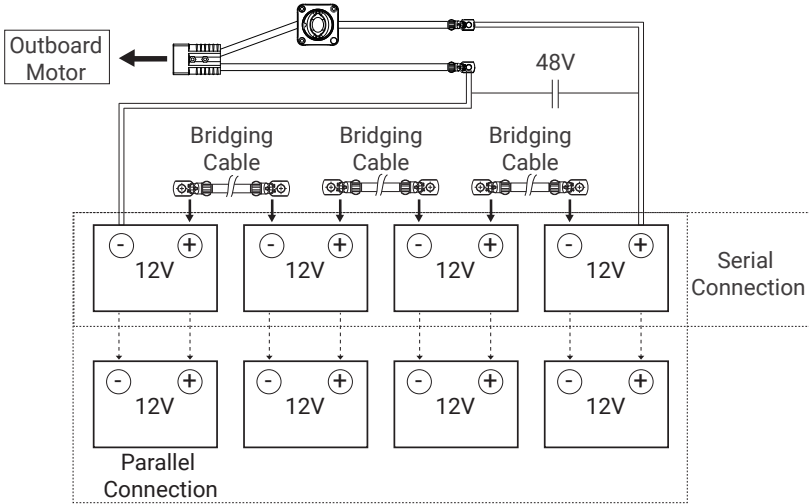





Figure 4-3

-  Do not short-circuit the main switch with other power supplies. The main switch should be mounted on the boat, and the back plate of the main switch should not be removed.
-  Only use the same batteries (same model, same capacity, same age and same manufacturer) in series and/or in parallel. Variations in batteries will cause damage.
-  Never reverse the polarity. Please pay more attention when connecting batteries in series and/or in parallel configuration. Always double check by referring to Figure 4-3.



## 5 Evo Remote Control/Evo Tiller

The Evo Remote Control and Evo Tiller is used for starting and stopping the outboard motor, adjusting the speed of the motor, configuring the battery parameters, displaying the system information and messages, etc. The Evo Remote Control is powered by either solar power or the built-in lithium battery, but the Evo Tiller is powered by connecting to the outboard with a communication cable. Evo Remote Control wirelessly or wiredly communicates with the outboard control system built in the main outboard motor, and Evo Tiller can only wiredly communicate with the outboard. The Evo Tiller itself owns the steering capability, while using the Evo Remote Control, it requires an additional steering wheel to help steer.

### 5.1 Display Panel

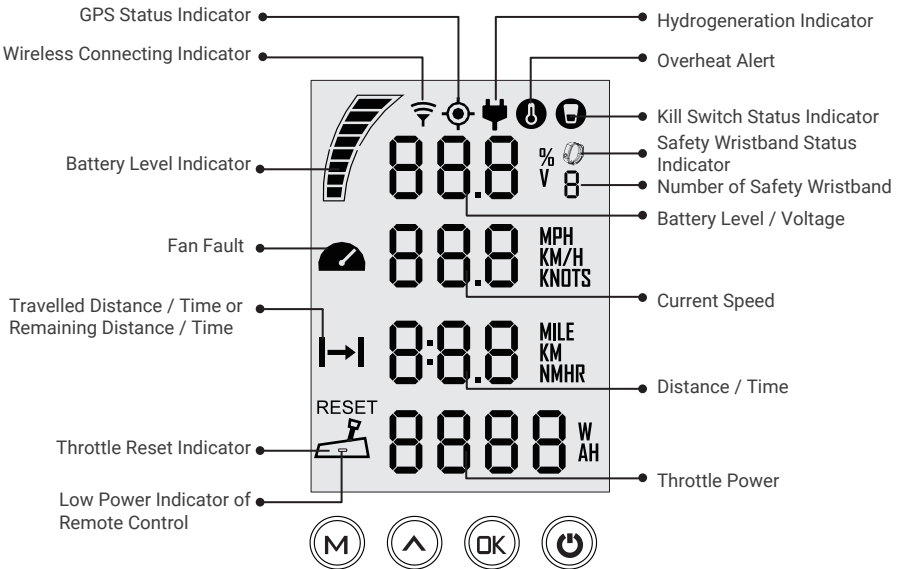



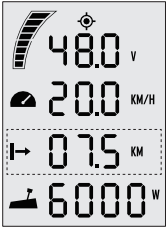

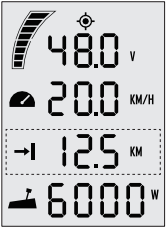
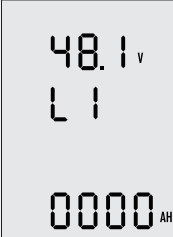























Figure 5-1









Buttons	Functions
 "Power"	<ol style="list-style-type: none"> <li>1. In power-off state, press and hold the power button to power on the Evo Remote Control or Evo Tiller.</li> <li>2. In power-on state, press and hold the power button to power off the Evo Remote Control or Evo Tiller.</li> <li>3. In power-on state, press the power button to switch on or off the backlight of Evo Remote Control or Evo Tiller.</li> </ol>
 "OK"	<ol style="list-style-type: none"> <li>1. On setting pages, press "OK" button to save the current settings and switch to the next item.</li> <li>2. On setting pages, press and hold "OK" button, and the system will save your settings, the display will exit from setting page and return to the home page.</li> <li>3. If home page displays or all characters display on the page, press "OK" button and hold <b>5s</b> to enter the pairing page.</li> <li>4. On home page, press "OK" button to switch between voltage V and battery percentage %.</li> </ol>
 "Up"	<ol style="list-style-type: none"> <li>1. On any setting page, press "▲" button to view options for current setting.</li> <li>2. In power-on state, when home page displays, press "▲" button and hold <b>10s</b> to enter the throttle calibration page.</li> <li>3. On home page, press "▲" button to switch the travelling distance or time displaying icon between "→ " and " →".</li> </ol> <div style="display: flex; align-items: center; justify-content: center; margin-top: 20px;"> <div style="text-align: center;">  <p>Main page 1</p> </div> <div style="margin: 0 20px; text-align: center;"> <p>press "Up" button</p>  </div> <div style="text-align: center;">  <p>Main page 2</p> </div> </div>

Buttons	Functions
<p><b>M</b> "Menu"</p>	<p>1. In power-on state, press and hold "M" button to enter the preference setting page.</p> <div data-bbox="528 232 699 467" style="border: 1px solid black; padding: 5px; text-align: center;">  </div> <p style="text-align: center;">Preference setting page</p> <p>2. On preference setting page, press and hold "M" button to enter the battery setting page.</p> <div data-bbox="524 592 695 829" style="border: 1px solid black; padding: 5px; text-align: center;">  </div> <p style="text-align: center;">Battery setting page</p> <p>3. On any page, press "M" button to return home page.</p>

 If users enter the page without setting any parameters, the current parameters displayed on the page will be saved as user parameters by default.

Icons	Functions	
	<p>Battery level indicator</p>	<p>Indicating approximate battery level. The solid blocks stand for remaining battery.</p>
	<p>Battery level/voltage</p>	<p>Indicating accurate current battery level percentage/battery voltage, is configurable in preference setting page.</p> <p>For example:</p> <p>100%: indicates current battery level.</p> <p>48.0 v: indicates current battery voltage.</p>

Icons	Functions	
	GPS status indicator	<ul style="list-style-type: none"> <li> Hidden: no satellite signal is received or GPS does not work.</li> <li> Blink: GPS is connecting to satellites. Shown constantly: GPS is in use.</li> </ul>
	Fan fault	<ul style="list-style-type: none"> <li> Blink: The motor fan has faults. Please contact the dealer to check the fan wiring.</li> </ul>
	Over-heat alert	<ul style="list-style-type: none"> <li> Hidden: system temperature is in normal range.</li> <li> Blink: system temperature is a little high and the maximum input power of motor has been lowered</li> <li> Shown constantly: system is over temperature and the outboard will stop working. The outboard can't be started until the system temperature drops to a certain level.</li> </ul>
	Kill switch status indicator	<ul style="list-style-type: none"> <li> Hidden: kill switch is present and is working well.</li> <li> Shown constantly: the kill switch is detached.</li> </ul>
	Current speed	Displaying real time cruising speed. Set units (KM/H, MPH or KNOTS) in preference setting page.
	Distance/time display	Displaying real time travel distance/time. Set units (MILE, KM (kilometer) and NM (nautical mile)) in preference setting page. The time unit is HR (hour).
	Travelled distance/time or remaining distance/time	<ul style="list-style-type: none"> <li> Remaining distance or time that the outboard can travel. Set units (MILE, KM (kilometer) and NM (nautical mile)) in preference setting page.</li> <li> Travelled distance or time.</li> </ul>

Icons	Functions	
	Throttle Power	<p>Displaying real time input power to the system.</p> <p>A blinking "RESET" indicating the throttle should be reset to zero position.</p>
	Wireless connecting indicator	<p>Displaying the remote control is wireless connecting with outboard.</p>
	Safety wristband connecting display	<p> Shown constantly: the safety is connecting with the remote control successfully.</p> <p> Blink: there is a safety wristband to disconnect.</p> <p>The number indicates the number of safety wristbands connected to the remote control.</p>
	Hydro generation indicator	<p> Shown constantly: the hydro generation function is turned on.</p> <p> Blink: the machine is charging the battery.</p> <p> Hidden: the hydro generation function is turned off.</p>

## 5.2 Charging the Evo Remote Control

The Evo remote control has an in-built lithium battery for power supply. The battery will be charged automatically under normal use: get charged by solar power or wired connection.

### 5.2.1 Charging by Solar Power

When the solar panel receives enough sunshine, it will generate electricity to charge the in-built lithium battery.

 Face the solar panel of the Evo remote control toward sunlight to get better charging effect.

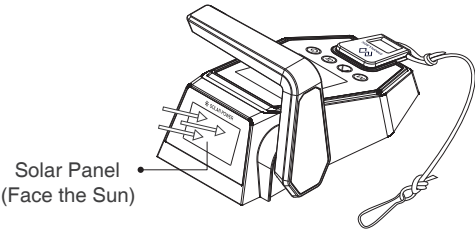



Figure 5-2

 Charging by solar power is recommended.

### 5.2.2 Charging by Wired Connection

If the Evo remote control can't get enough solar power for a long time, the battery will run out. In this case, error code E60 (Figure 6-3) will display to remind you to charge the Evo remote control.



Figure 5-3

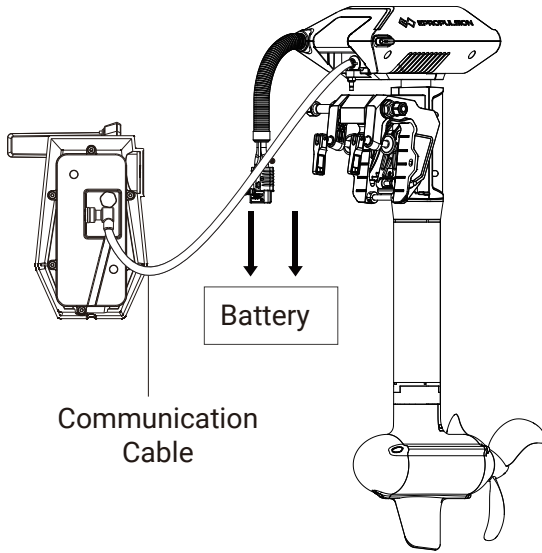







Figure 5-4

-  During long-term storage, ensure to charge the control system every 6 months to avoid over-discharge.
-  Do not short-circuit the main switch with other power supplies. The main switch should be mounted on the boat, and the back plate of the main switch should not be removed.
-  After long-term storage, charge the control system before use.
-  The communication cable is not included in this package. Please purchase one from your dealer if you choose this charging method.
-  Once the communication cable disconnects, charging automatically stops and the running motor stops. Please restart the motor.

## 5.3 Power Adjusting

### 5.3.1 Power Adjusting for Evo Control System



Please place the safety switch on the Evo control system before operation.

The Evo Control system is mainly used to adjust the input power of the motor. When the battery is well connected and switched on, power on the control system to start the outboard, then slowly push/rotate the throttle forward position to increase the power. The maximum forward/backward power is shown below.

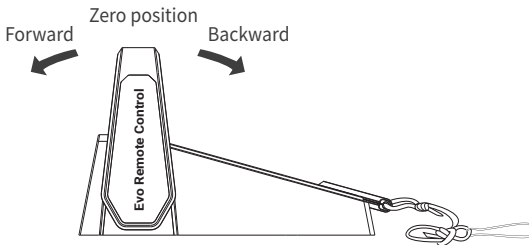

Figure 5-5

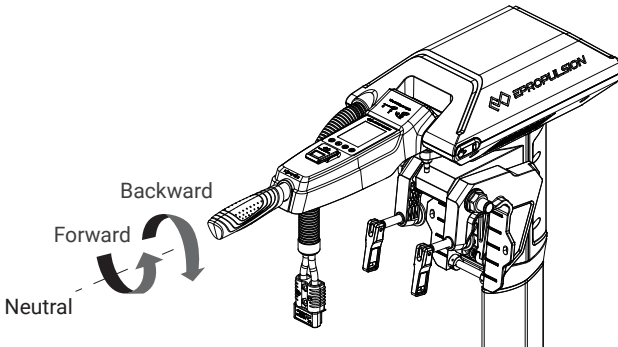

Figure 5-6

Model	Max Forward Power	Max Backward Power
NAVY 3.0 Evo	3 kW	3 kW
NAVY 6.0 Evo	6 kW	6 kW



Before power on the Control system, please reset the throttle to zero position.



If you find a blinking “RESET” on the display panel, you are reminded to reset the throttle to zero position.



If you pull the throttle from the forward position to the backward position directly, the motor will first stop shortly, then start turning to the reverse direction.



### 5.3.2 Recalibration

If the error code displays as the figure 5-7, users should calibrate the throttle **strictly** as below steps.



 Before calibration, please detach the kill switch from the control system.



Figure 5-7

Recalibration process	LCD Displaying
<p>Step1: Long press "▲" button for 10s until "CAL FO" displays.</p>	
<p>Step2: Push the throttle to the maximum forward power position, then press "OK" button. "CAL 5t" will display and "CAL" will be blinking.</p>	
<p>Step3: Pull the throttle to the middle (zero) position where you can hear a click sound, then press "OK" button, "CAL bA" will display and "CAL" will be blinking.</p>	
<p>Step4: Pull the throttle to the maximum backward power position, then press "OK" button. It will return to the main page automatically.</p>	

## 5.4 Use of Kill Switch

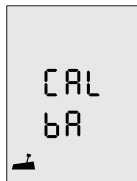
- Attach the kill switch and tie its lanyard to your wrist or life jacket.
- Stop the outboard in emergency by detaching the kill switch.
- To run the motor again, first attach the kill switch then start the motor.

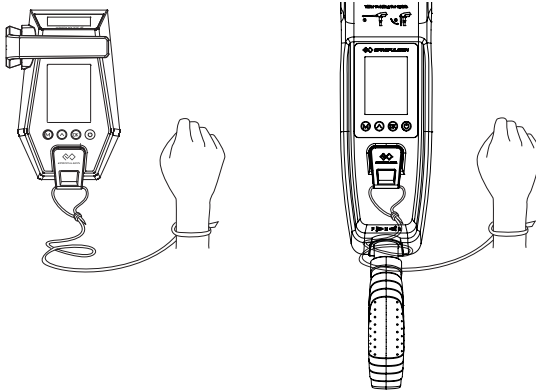

Figure 5-8

- ⚠ The kill switch generates magnetic field. Keep it 50cm / 20inches away from medical implants like pacemakers and magnetic cards (e.g. credit card) as well as other magnetic media.
- ⚠ The magnetic field of the kill switch may interfere with some electronic instruments. Keep it away from these electronic instruments.

## 5.5 Use of Safety Wristband

### 5.5.1 Pairing Safety Wristband with Evo Control System

Press the “**^**” and “**OK**” buttons and hold for a while to display the safety wristband icon and “SE”. At this time, approach the safety wristband that needs to be paired, turn on the safety wristband, and the Evo control system displays the “SUC”, indicating successfully pairing. Keep in this interface and continue to press “**OK**” to pair the safety wristband continuously (the maximum number of pairs is 8). After completing the pairing, press the “**M**” button to return to the main page.

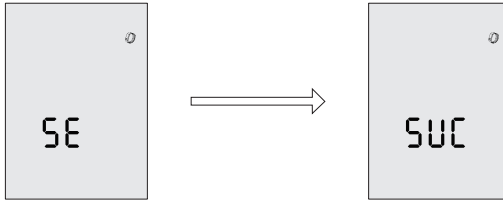

Figure 5-9

### 5.5.2 Man Overboard Protection

After the safety wristband and the Evo control system are paired, when the safety wristband falls into the water and the Evo control system is on, the outboard will stop immediately. The Evo control system display will flash with a buzzing sound. The safety wristband icon flashes and the number of safety wristbands decreases. At this time, you can continue to operate the machine by returning the throttle to zero position. The buzzer of the Evo control system will stop, but the display continues to flash. If you confirm that you need to cancel the alarm state, please restart the Evo control system or the disconnected wristband.

### 5.5.3 Emergency Stop

After the safety wristband and the Evo control system are paired, when the Evo control system is in operation, short press the button of the safety wristband, the outboard will stop immediately. The display of the Evo control system will flash with a buzzer. At the same time, the safety wristband icon flashes and the number of safety wristbands displayed at the bottom decreases. At this time, you can continue to operate the machine by returning the throttle to zero position. The buzzer of the Evo control system stops, but the display continues to flash. If you confirm that you need to cancel the alarm state, please restart the Evo control system or short press the safety wristband after 5 seconds.



When a wristband is disconnected or an emergency stop is performed, the stop command of other wristbands will not work until it returns to the normal state.

## 5.6 Pairing Evo Control System with the Outboard

Before use please pair control system with the outboard. Evo Tiller will automatically pair with the outboard after mounting on the outboard properly. There are two methods to pair the remote control with the outboard. Please choose one of the two methods and follow the steps to build new communication.

### Method 1. Pairing without Communication Cable

**Step1:** Switch off system power and hold the remote control within 0.5m of the outboard.

**Step2:** Press and hold the “” button to switch on the remote control.

**Step3:** Ensure the wireless indicator is shown constantly on the home page.

**Step4:** Press “” button and hold **5s** to enter the pairing setting page (Figure 6-9).

On this page, you can find the blinking “Add” and “RUF”, and a countdown timer “060” (60s).



Figure 5-10

**Step5:** Switch on system power. Wait for them to get paired in seconds.

**Step6:** After pairing, the LCD panel will display as Figure 6-10 for 5s, then returning to home page automatically.



Figure 5-11



If pairing fails within 60s, go back to **Step4** and try again.

## Method 2. Pairing with Communication Cable

**Step1:** Switch off system power and the remote control.

**Step2:** Connect the remote control and the Communication module with a communication cable.

**Step3:** Switch on system power and the remote control. Wait for them to get paired in seconds. Pairing succeeds when home page displays.

💡 No matter it is in wireless communication status or not, it will switch to wired communication status when you are pairing with a communication cable.

💡 If the control system or the outboard is replaced with a new one, the original wireless link will break and wireless communication failure will occur. The main page of the LCD panel on the Control system will display as below. In this case, users should conduct pairing again.

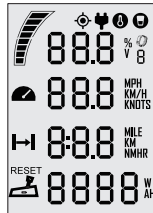

Figure 5-12

However, if the Control system and the outboard are not replaced, but the LCD panel still displays like this, you should check and:

- 1) Make sure the Control system is not far from the outboard motor;
- 2) Make sure all the equipment involved is normally powered on.

If the Control system still displays like Figure 6-11 after check, it indicates an error has occurred. Please contact your dealer for repair.

# 5.7 Hydro Generation Function

NAVY Evo outboard can drive the propeller to charge the battery (only the ePropulsion battery) through water flow.

**The machine will enter the hydro generation state if the following conditions are met:**

1. The Evo control system is set to turn on the hydro generation function (enabled by default).
2. The Evo control system is in the zero position.
3. The ePropulsion battery power is below 90%.
4. The machine will enter the hydro generation state after the boat speed is above 6km/h stable for 4 seconds.
5. The hydro generation function can be used only when connecting ePropulsion batteries.
6. If using E-series battery, please connect with a communication cable.

**When any of the following conditions occur, the hydro generation will be stopped:**

1. The Evo control system is set to turn off the hydro generation function.
2. The Evo control system is in the forward / backward state (not in the zero position).
3. The ship is not traveling or traveling too fast (NAVY 3.0 Evo is higher than 40km/h or NAVY 6.0 Evo is high than 45km/h).
4. The battery level is higher than 90%.

 Only when connecting with ePropulsion batteries, the hydrogeneration function can be turned on.

## Set up the hydro generation function

When the Evo control system and the machine are successfully connected, and the Evo control system and the outboard are both on. Press the “M”, “^” and “OK” buttons at the same time to enter the hydro generation setting interface. Then press “OK” to change the state of the hydro generation function (En means on, Dis means off).

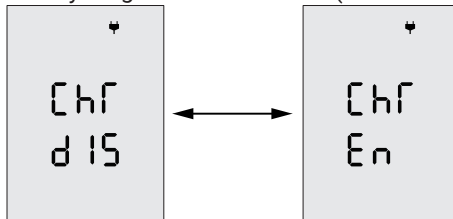

Figure 5-13

## 5.8 Warning Messages

When the outboard motor is running in abnormal conditions or out of order, a warning message with an error code will display on the LCD panel. Figure 6-13 is an example. Please find more error codes and corresponding solutions in the below table.



Figure 5-14

Code	Cause	Solution
E01	Battery voltage beyond operation range.	Replace a battery based on suggested operation specifications.
E02	Propeller may be blocked, causing motor overcurrent	Refer to Solution to E10.
	Motor fails or circuit board fails causing motor overcurrent	Try to turn off the main switch and wait for 10 seconds then turn on the switch again.
E06	The battery voltage level is too low.	Operate the motor at low power. Please charge the battery as soon as possible.
E10	Motor stall, which may be caused by blocked propeller	Turn off power, then clean up the things winding around the propeller. Test if the propeller can be rotated by hand before operation.
E11	The temperature of motor is too high.	Stop operating the outboard and wait until the temperature falls within the normal operating temperature range.

Code	Cause	Solution
E12	The temperature of circuit board is too high.	Stop operating the outboard and wait until the temperature falls within the normal operating temperature range.
E22	MCU Communication Abnormality	Please restart to see if the error disappears, if not, please contact your dealer for help.
E30	Throttle position sensor failure, should recalibrate the throttle position sensor.	Please refer to section 6.3.2 <i>Recalibration</i> to recalibrate the throttle position sensor.
E56	Communication Error between outboard and battery	Check if the communication cable between outboard and battery is well connected, if yes, please restart the system.
E60	The remote control is running out of power.	Please connect the remote control to the outboard by a communication cable. Please refer to section 6.2.2 <i>Charged by Wired Connection</i> .
All characters display	The motor has no power.	Connect the battery to the outboard and then turn on the main switch.
	Not paired	Please refer to section 6.6 <i>Pairing Control System with the Outboard</i> .

 If the problem persists, please consult your ePropulsion authorized dealer for assistance.



## 6 Configurations

### 6.1 Preference Settings

It's advised to set display preference by these steps before operation.

**Step1:** In power-on state, press “M” button and hold to enter the preference setting page as shown in Figure 6-1. Users can choose display items based on personal needs and preference.

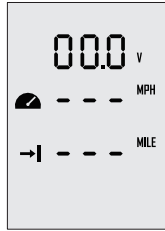

Figure 6-1

**Step2:** On the preference setting page, the blinking item is the object waiting to be set. Press the “^” button to view options for the blinking item. For example, in Figure 6-1, if “V” is blinking on the preference setting page, it means that “V” has other alternate options. Just press the “^” button, and “V” will switch to “%”, i.e. the displayed item is switched from voltage to battery level.





**Step3:** Press “OK” button to save setting for the current item and skip to the next item simultaneously.

**Step4:** When all the items have been set well, long press the “OK” button to save all the settings and return to the main page.

### 6.2 Battery Configuration

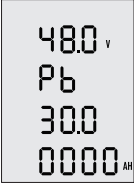
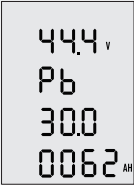
Accurate battery configuration helps achieve precise estimation of the battery's discharging state. When using an ePropulsion E Series Battery, battery configuration is self-activated by the control system given that all the communication cables are well connected. When not using E Series Batteries, users should manually configure the batteries via Remote Control/Tiller at the first time use, so the battery level will display more accurate.

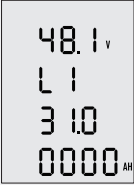
**⚠** Battery configuration should be carried out if a battery with different type/capacity/voltage is connected to NAVY 6.0 for the first time.

Battery Configuration Process	LCD Displaying
<p><b>Step1:</b> First, turn on the main switch and the Evo Remote Control / Evo Tiller.</p> <p>Press and hold the “<b>M</b>” and “<b>OK</b>” button simultaneously to enter the battery setting page. Users can see the attery type blinking and it’s ready for configuration.</p>	
<p><b>Step2:</b> Press “<b>OK</b>” and “<b>^</b>” button to set the nominal voltage.</p>	
<p><b>Step3:</b> Press “<b>OK</b>” button to switch the battery type options between Pb, Li and LFE.</p> <p><b>Pb:</b> Lead-acid battery    <b>Li:</b> Lithium battery  <b>LFE:</b> Lithium-ion ferrous phosphate battery</p>	
<p><b>Step4:</b> Press “<b>OK</b>” and “<b>^</b>” button to set the battery cut-off voltage.</p>	
<p><b>Step5:</b> Press “<b>OK</b>” and “<b>^</b>” button to set the battery capacity according to the battery you use.</p> <p>Note that the unit of capacity is “Ah”, usually the capacity of battery is expressed in “Wh”, and we can get the capacity in “Ah” by following the below formula:</p> $\text{Capacity in Ah} = \frac{\text{Capacity in Wh}}{\text{Nominal voltage in V}}$ <p>Eg. if users use a 3000Wh Lithium battery with 48.1V nominal voltage, then the battery is about 62.37Ah, so you can set 62Ah as the capacity setting.</p>	

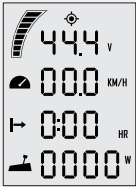
Battery Configuration Process	LCD Displaying
<p><b>Step5:</b> Press “M” button to save all the settings and return to the main page.</p>	

 Lithium batteries, lead acid batteries and lithium iron phosphate batteries are recommended to use with NAVY Evo. Other types of battery may fail to make NAVY Evo work properly.

 When you use the below batteries, please set battery type and rated voltage value based on the parameters in the following table.

Battery type	Nominal Voltage options										
LI	43.2V	44.4V	45.6V	46.8V	48.1V	49.4V	50.4V	51.8V	53.2V		
Pb	44.0V	46.0V	48.0V	50.0V	52.0V	54.0V					
LFE	44.8V	48.0V	51.2V								

 Update the battery configuration is necessary if a different type of battery has been applied.

 When using non-ePropulsion batteries, before starting the outboard, users should configure the batteries via the Evo Control System for the first time use, otherwise the batteries may not work properly.

## 7 Checklist before Use

---

1. Ensure the propeller is correctly and firmly mounted on the outboard.
2. Ensure the outboard is correctly and firmly mounted on the boat.
3. Ensure the throttle and steering wheel are installed in proper position before turning on the power.
4. Ensure the throttle travels smoothly with no obstacles.
5. Before connecting the battery, check and make sure there is no poor contacts or defects in cables.
6. Check and ensure the main switch is able to power on and off normally. After that, turn off the main switch.
7. Ensure the battery has enough power.
8. Ensure the Evo Remote Control has enough power when the Remote Control is wirelessly connecting to the outboard.



Start the outboard only when the propeller is beneath water, as the rotating propeller is dangerous.



If the cable is immersed in water, please dry it completely before connecting it to the battery or power on the system.

## 8 Starting the Outboard

---

1. Complete the check list.
2. Remove the kill switch from the Remote Control/Tiller.
3. Push/Turn the throttle to zero position.
4. Connect the battery to the outboard.
5. Fix the outboard with a proper trim angle.
6. Turn on the main switch. If the outboard is connected to an E Series Battery, please also press the battery power button to power on.
7. Press “” button to turn on the Remote Control/Tiller and the main page will display.
8. Carry out preference setting and battery configuration if necessary.
9. Tie the kill switch to your wrist or life vest, then attach the kill switch on the Remote Control/Tiller.
10. Push/Turn the throttle slowly to start your outboard.

## 9 Stopping the Outboard

---

Usually, it's recommended to stop the outboard as the following procedures.

1. Return the throttle to zero position.
2. Wait until the outboard stops, then detach the kill switch from the Remote Control/Tiller Handle.
3. Press and hold the “” button until the Remote Control/Tiller Handle is powered off.
4. Turn off the main switch. If the outboard is connected to an E Series Battery, please also press the battery power button to power off.
5. Tilt the outboard above water surface or detach it from boat.



If the outboard motor will not be used soon, it's recommended to tilt the outboard out of water, otherwise erosion may occur.



The outboard will stop if one of the situations occurs.

1. The throttle is in zero position.
2. The kill switch is not in the correct position of Remote Control/Tiller Handle.
3. The main switch is off.
4. The communication between Remote Control/Tiller Handle and outboard breaks.
5. The connection between battery and outboard breaks.
6. Failure exists in the control system (e.g. motor is blocked or the low battery voltage level is detected).

# 10 Trim Angle Adjusting

---

 Only adjust the outboard trim angle when the outboard is stationary.

There are five trim angle options including 60°, 15°, 10°, 5° and 0°. Adjust the outboard trim angle based on specific conditions. E.g. when the boat is in shallow water or the outboard is not in use, tilt the outboard and adjust the trim angle to 60°. For normal operation, fix it to a proper trim angle where the shaft is vertically downward during operation. Be reminded that the best trim angle varies by boat type, operation conditions, weather, etc.

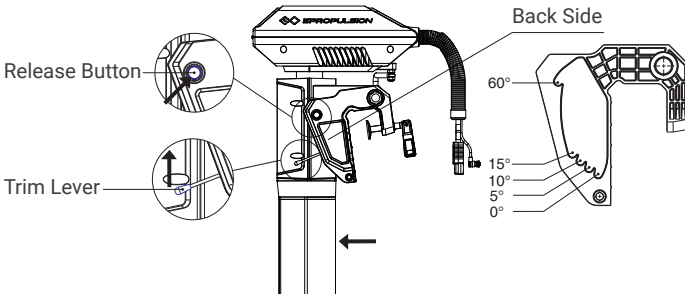



Figure 10-1

## Tilting up

 Detach the Tiller first before tilting the outboard motor up to the position with max trim angle.

 Do not use the tiller handle to tilt or lift your outboard. The tiller handle is not designed to support the weight of the outboard, and damage may occur. Please use the cowling to support the weight of the outboard while lifting and tilting.

Pull up the trim lever with one hand, and lift the outboard shaft with the other hand to enlarge the trim angle to a particular degree. Then, release the trim lever to lock the trim angle.

## Tilting Down

The release button is raised when the trim angle is maximum at 60° position.

If the trim angle is not greater than 15°, lift the outboard shaft with one hand, then pull up the trim lever to the highest position with the other hand to reduce the trim angle to a particular degree. Then release the trim lever to lock the trim angle.

If the trim angle is greater than 15°, press the release button and tilt up the propeller shaft slightly to about 80° position, then lay it down, and the outboard shaft will return to 0° position.



It's suggested to test with different trim angles to find the optimal trim angle for the boat and operation. Note that the speed should be increased gradually during the test, and check if there are any abnormal situations. Stop the outboard and decrease the trim angle if necessary.



Slight and gentle operations are recommended when tilting up and down.



The trim lever is used to increase the trim angle from 0° to 60° or reduce the trim angle from 15° to 0°.

# 11 Anti-grounding Mode

---

When the boat runs in shallow water or in complicated underwater conditions, it may meet grounding dangers. Setting the outboard to anti-grounding mode will protect the outboard motor from damage if the outboard hits submerged reefs or rocks. In anti-grounding mode, the underwater part of the outboard is flexible in tilting direction and the motor will automatically tilt up if it hits something underwater.

Step 1: Use the left hand to pull the gear hook to turn it through a certain angle to ensure that the beach structure wrench can be pulled down to the end of the stroke.

Step 2: Use your right hand to pull down the beach structure wrench to the end of the stroke (pull up to exit the beach).

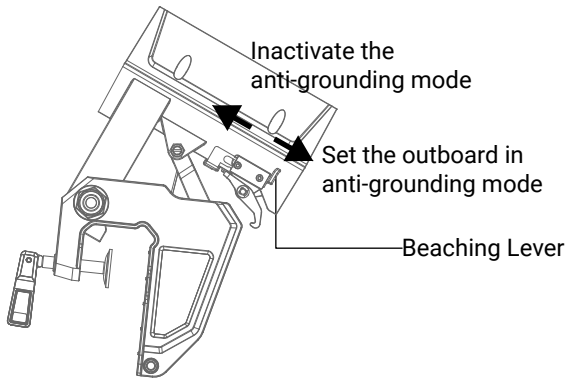



## 12 Thread the communication cable into the bellow

In order to protect the cable and the beauty of the machine, it is recommended that when using a 5m communication cable, follow the following operations to thread the communication cable into the bellow:

Step 1: Remove the handle shaft, the decorative cover and the upper case, remove the card holder, and thread the cable through the bellow (it is recommended to insert the hard line into the bellow first to help thread the communication cable).

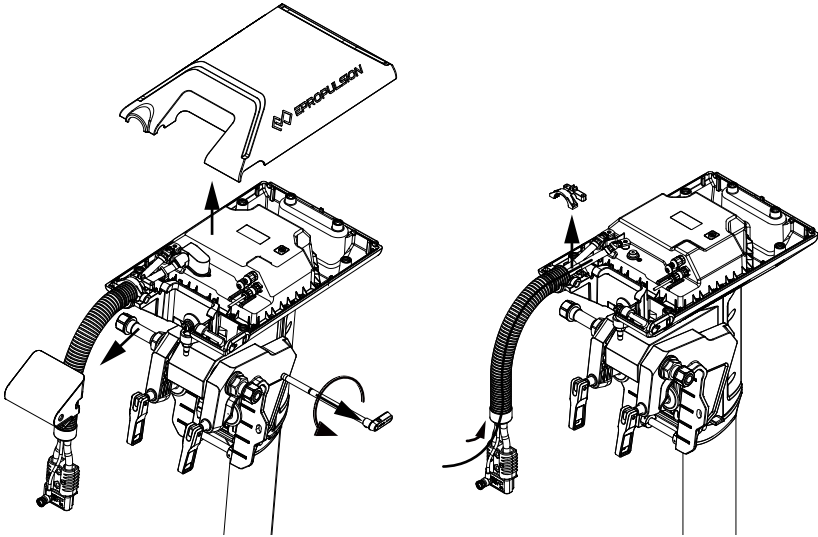

Figure 12-1

Step 2: Put the cable into the card wire slot, and then put it into the cable hole of the lower case.

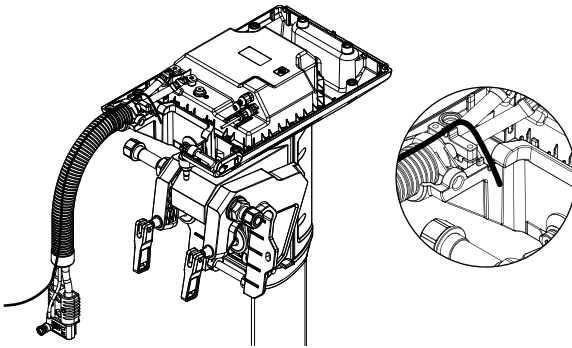

Figure 12-2

Step 3: Install the upper case, and then install the decorative cover, thread through the two cable holes as shown in the figure, and finally connect to the communication port.

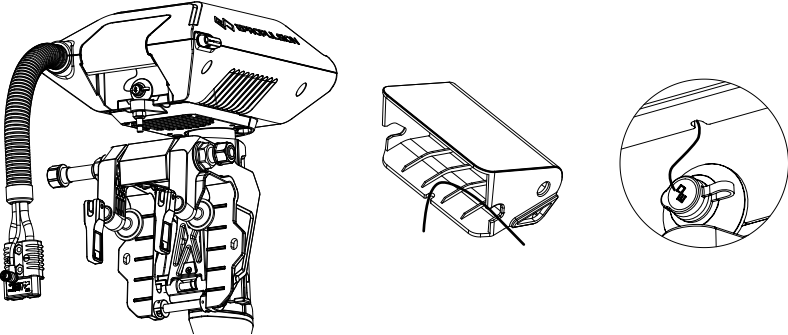

Figure 12-3

# 13 Maintenance

## 13.1 Notes

Regular maintenance is beneficial to keep your outboard working in optimal condition.

Do not start the outboard in shallow or unknown water conditions. Only use the outboard in deep water area.

In order to clean and reduce corrosion, use fresh water to wash the whole outboard after use in salt water.



Regularly check whether the propeller is damaged, whether there is a fishing line entangled. The motor is out of warranty due to the fishing line causing water to enter the motor.



Disconnect the battery from outboard before maintenance.



Conduct the maintenance under instructions of professional experts or your dealer.



Only use ePropulsion original components for replacement and maintenance.

## 13.2 Maintenance Time Table

Regularly maintained in proper manner and used in normal condition, the outboard can work at its optimal state. The following table shows a general maintenance frequency, which however may vary according to operating conditions.

Item	Operations	Initial	Every	
		50 hours (3 months)	100 hours (6 months)	200 hours (12 months)
Anode	Check/Replace	□	□	■
Propeller and pin	Check/Replace	□	□	■



The “□” symbol indicates checks may be carried out by users. The “■” symbol indicates work to be carried out by your dealer.

### 13.3 Propeller Maintenance

 Disconnect the battery with outboard before maintenance.

 Gloves are recommended to protect your hand from sharp propeller edges.

Check the propeller according to the following instructions, then refer to then refer to *section 2.2 Selecting and Mounting the Propeller* to replace a new propeller if necessary.

1. Check the propeller blades for wear, cavitation erosion and other damage.
2. Check the pin for wear and damage.
3. Check for water plants, fishing net or line twine around the propeller.
4. Replace a new anode if necessary.

### 13.4 Replacing the Anode

Please refer to the figure below to replace a new anode if necessary.

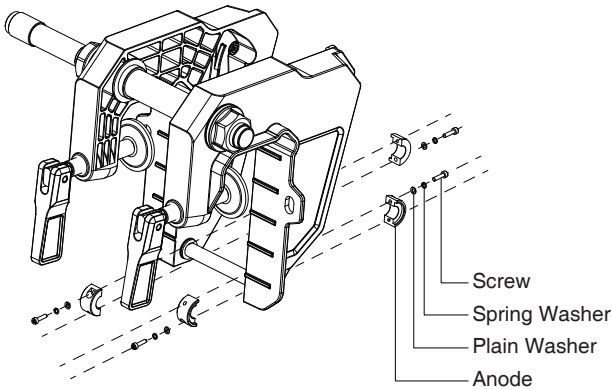

Figure 13-1

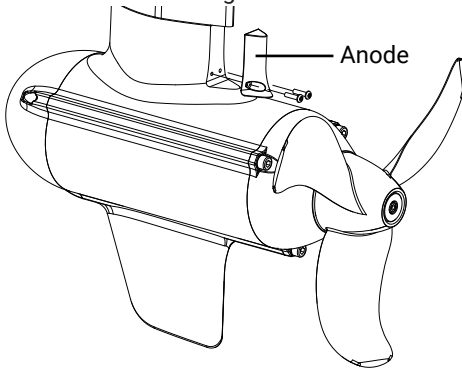

Figure 13-2

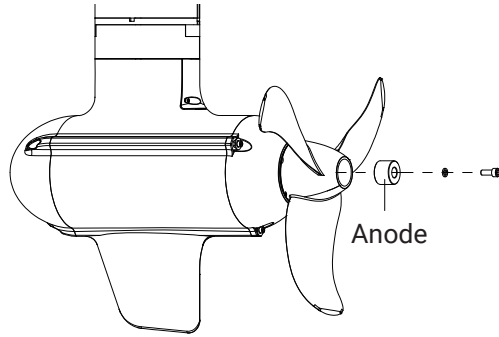

Figure 13-3

## 13.5 Maintenance of Electrical Contacts

Clean all electrical contacts with electrical contacts cleaner every two months, and clean immediately once there is rusty show up.

# 14 Transportation and Storage

---

## 14.1 Transport

For long distance transport, please use the ePropulsion original packing materials to pack the outboard before delivery.

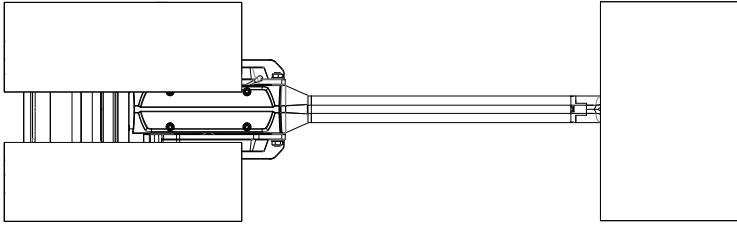

Figure 14-1

## 14.2 Placement

When placing the outboard on a surface, ensure the surface is flat and horizontal. It's better to put some damping cushion underneath.

## 14.3 Storage

If you are not using the outboard motor for more than 2 months, it's advised to contact your dealer to clean and check the outboard prior to storage. It's recommended to pack the outboard with ePropulsion original packing materials for storage.

**⚠** Get adequate damping protection measures before transport and storage. And ensure the propeller receives no pressure if the propeller is mounted on the propeller shaft.

**⚠** Store the outboard in a well-ventilated and dry area without direct sunshine.

**⚠** Ensure the ambient temperature is proper (-25°C~50°C) during storage.

# 15 Emergency Situations

---

## 15.1 Collision

If the outboard strikes some object beneath the water, please follow below procedures.

1. Stop the outboard immediately and then turn off the main switch.
2. Check the mechanical structure to see if there are damages.
3. Return to the nearest harbor or pier in low power.
4. Call your dealer to check the outboard.

## 15.2 Sodden Outboard

If the outboard is sodden, stop it immediately and turn off the main switch then disconnect the battery. Bring the outboard to the dealer. And ensure the outboard is thoroughly inspected before operating it again.

## 15.3 Low Battery Level

When the battery voltage is lower than 42V, the throttle power will be limited gradually along with the voltage drop. When the battery voltage drops below 39V, the outboard will stop automatically to prevent battery over-discharge. If this happens when the outboard is far away from the shore, and there is an alternative battery, it's recommended to wait until the battery voltage recovered to 42V or above. You can restart the outboard with throttle power below 1000W.

## 15.4 Over-temperature Protection

When the operating temperature is high, the max input power will be limited within rated power, and the power will decrease with the rise of temperature. If the system temperature keeps rising and surpasses a threshold, the outboard motor will shut down automatically to avoid over-temperature. Users should stop operating the outboard and wait until the temperature falls within the normal range.





# 16 Warranty

The ePropulsion limited warranty is provided for the first end purchaser of an ePropulsion product. Consumers are entitled to a free repair or replacement of defective parts or parts which do not conform with the sales contract. This warranty operates in addition to your statutory rights under your local consumer law.



## 16.1 Warranty Policies

ePropulsion warrants its products to be free of defects in material and workmanship for a limited period since the date of purchase. Once a fault is discovered, the user has the right to make a warranty claim under the ePropulsion warranty policies.

Product	Warranty Expiry Date
NAVY 3.0 Evo NAVY 6.0 Evo	<b>Two years</b> after the date of purchase (uncommercial).
Components have been repaired or replaced	<b>Three months</b> since the date of maintenance. Note: 1. If the three-month period overlaps with the original warranty period, the warranty against these replaced or repaired parts still expires two years after the date of purchase. 2. If the three-month period exceeds the original warranty period, the repaired or replaced parts continue applying to warranty during the extended period.

-  In order to validate the warranty, users are required to fill in the Warranty Card in the package in advance.
-  Keep the product label in intact state and record the serial number on the label. Never tear the label off the product. An ePropulsion product without the original product label will not be applicable to warranty services provided by ePropulsion.
-  The warranty is valid only when the information is correct and complete.
-  Free warranty is only validated upon the presentation of legal serial number, Warranty Card, and evidence of purchase from an authorized ePropulsion dealer.



-  Valid date of purchase should be established by the first-hand purchaser with original sales slip.
-  Free warranty is not transferable and will not be reissued.
-  Within the limits of the applicable laws, the warranty policies of ePropulsion may update without prior notice. The latest version is available at our website [www.epropulsion.com](http://www.epropulsion.com).

## 16.2 Out of Warranty

Make sure the product is properly packed during delivery, the original ePropulsion package is recommended. If the product got further damaged due to improper packing during delivery, the furtherly damaged part will be deemed as out of warranty coverage.

In addition, faults or damages caused by the following reasons are also excluded from warranty scope within the covered period:

- Any improper operation contradicts the user manual.
- Accident, misuse, wishful abuse, physical damage overcharging, liquid damage or unauthorized repair.
- Dropping, improper care or storage.

 You should be noted that minor faults like normal wear and tear that pose no influence on the intended function of the product are also not covered by the warranty.

 Consumables are out of warranty scope.

## 16.3 Warranty Claim Procedures

If you find your product defective, you can make a claim to your dealer following below procedures:

1. Fill in the Warranty Card correctly and completely in advance. Then make your warranty claim by sending it to your authorized ePropulsion service partner together with valid proof of purchase. Usually these documents are required when making a warranty claim: the Warranty Card, ex-factory serial number, and evidence of purchase.

2. Send the defective product to your authorized ePropulsion service point after getting the confirmation. Note that the label should be kept intact. You can also deliver the product to your authorized ePropulsion dealer after getting confirmation.
  3. The defective components or parts will be either repaired or replaced according to the diagnosis made by the ePropulsion authorized service partner.
  4. If your warranty claim is accepted, the equipment will be repaired or replaced free of charge. Note that any delivery cost incurred in the process is at your charge.
  5. After careful examination and confirmation by ePropulsion authorized dealer, the defective or faulty components will be repaired or replaced with brand new ones against the actual condition.
  6. In case your warranty claim be rejected, an estimated repair charge with round trip delivery cost will be sent for confirmation. ePropulsion authorized service point will conduct maintenance accordingly only after your confirmation.
-  If warranty expires, you can still enjoy maintenance services from authorized ePropulsion service partners with minimum maintenance charge.



Scan to register  
your product



Product  
tutorial

Thanks for reading this user manual.

If you have any concerns or find any problems while reading, please don't hesitate to contact us. We are delighted to offer service for you.

Vielen Dank, dass Sie diese Bedienungsanleitung gelesen haben.

Wenn Sie Fragen haben oder beim Lesen Unklarheiten aufkommen sind, zögern Sie bitte nicht, uns zu kontaktieren. Wir freuen uns, Ihnen behilflich sein zu können.

**Guangdong ePropulsion Technology Limited**

**Webseite: [www.epropulsion.com](http://www.epropulsion.com)**

**E-Mail: [service@epropulsion.com](mailto:service@epropulsion.com)**