

POD DRIVE EVO USER MANUAL
BEDIENUNGSANLEITUNG POD DRIVE EVO
Pod Drive 1.0 / Pod Drive 3.0 / Pod Drive 6.0

2022.11 Version 2.0

Copyright © 2022 ePropulsion. All Rights Reserved

Acknowledgement

Thanks for choosing ePropulsion products, your trust and support in our company are sincerely appreciated. We are dedicated to providing high-performance electric outboards, electric pod drives, sup/kayak motors, reliable lithium batteries and accessories.

Welcome to visit www.epropulsion.com and contact us if you have any concerns.

Using This Manual

Before use of the product, please read this user manual thoroughly to understand the correct and safe operations. By using this product, you hereby agree that you have fully read and understood all contents of this manual. ePropulsion accepts no liability for any damage or injury caused by operations that contradict this manual.

Due to ongoing optimization of our products, ePropulsion reserves the rights of constantly adjusting the contents described in the manual. ePropulsion also reserves the intellectual property rights and industrial property rights including copyrights, patents, logos and designs, etc.

This manual is subject to update without prior notice, please visit our website www.epropulsion.com for the latest version. If you find any discrepancy between your products and this manual, or should you have any doubts concerning the product or the manual, please visit www.epropulsion.com.

ePropulsion reserves the rights of final interpretation of this manual.

This manual is multilingual, in case of any discrepancy in the interpretation of different language versions, the English version shall prevail.

Symbols

The following symbols will help to acquire some key information.



Important instructions or warnings



Useful information or tips

Product Identification

Below picture indicates the serial numbers of Pod Drive Evo. Please note the position of the serial numbers and record them for access to warranty service and other after-sale services.

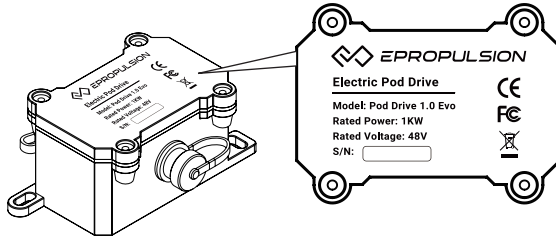

Figure 0-1

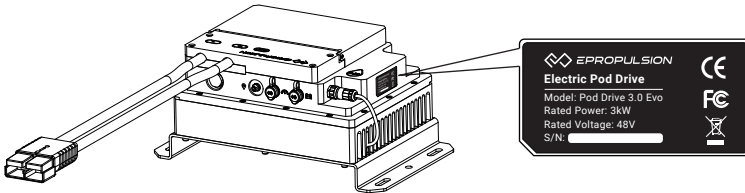

Figure 0-2

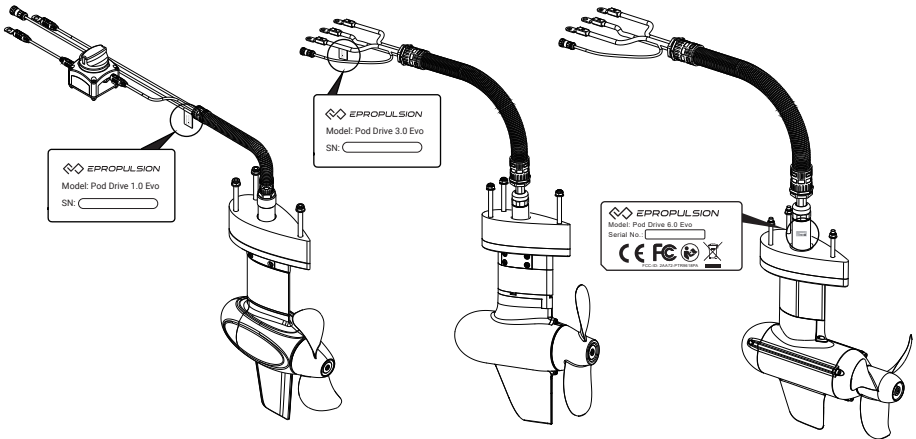

Figure 0-3

Figure 0-4

Figure 0-5

Table of Contents

| | |
|---|-----------|
| Acknowledgement | 1 |
| Using This Manual | 1 |
| Symbols | 1 |
| Product Identification | 2 |
| 1 Product Overview | 5 |
| 1.1 In the Package | 5 |
| 1.2 Parts and Diagrams..... | 8 |
| 1.3 Technical Data..... | 10 |
| 1.4 Declaration of Conformity..... | 11 |
| 1.5 Important Notes | 12 |
| 2 Checking the Propeller | 13 |
| 3 Mounting the Motor | 15 |
| 4 Connecting the Battery | 21 |
| 4.1 Connecting the E Battery | 21 |
| 4.2 Connecting a 48V Battery | 22 |
| 4.3 Connecting a SPIRIT Battery Plus (Only for Pod Drive 1.0 Evo) | 23 |
| 5 Evo Remote Control | 24 |
| 5.1 Display Panel | 24 |
| 5.2 Charging..... | 28 |
| 5.2.1 Charging by Solar Power | 28 |
| 5.2.2 Charging by Wired Connection | 28 |
| 5.3 Power Adjusting | 30 |
| 5.3.1 Power Adjusting for Evo Remote Control..... | 30 |
| 5.3.2 Recalibration | 31 |
| 5.4 Use of Kill Switch..... | 32 |
| 5.5 Use of Safety Wristband | 33 |
| 5.5.1 Pairing Safety Wristband with Remote Control | 33 |
| 5.5.2 Man Overboard Protection | 33 |
| 5.5.3 Emergency Stop..... | 33 |
| 5.6 Pairing Remote Control with the Pod Drive | 34 |

| | |
|--|-----------|
| 5.7 Warning Messages..... | 36 |
| 6 Configurations..... | 38 |
| 6.1 Preference Settings..... | 38 |
| 6.2 Battery Configuration..... | 38 |
| 7 Checklist before Use..... | 41 |
| 8 Starting the Pod Drive..... | 41 |
| 9 Stopping the Pod Drive | 42 |
| 10 Hydro Generation Function | 43 |
| 11 Maintenance..... | 44 |
| 11.1 Contents and precautions of daily maintenance | 44 |
| 11.1 Propeller Maintenance..... | 44 |
| 11.2 Replacing the Anode..... | 44 |
| 11.3 Maintenance of Electrical Contacts..... | 46 |
| 12 Transport and Storage | 47 |
| 12 Emergency Situations..... | 48 |
| 12.1 Collision | 48 |
| 12.2 Low Battery Level..... | 48 |
| 13 Warranty | 49 |
| Out of Warranty | 50 |
| Limited Warranty Claim Procedures..... | 50 |



1 Product Overview

Pod Drive 1.0/3.0/6.0 Evo are the electric pod drive system of 1kW/3kW/6kW input power, controlled by either Evo Remote Control or Evo Side Mount Control. Pod is gaining increasing population among boat owners in recent decades. But available premium electric pod systems are rare. Electric pod drives are environment-friendly, clean and very efficient. This electric pod drive system is equivalent of 3hp/6hp/9.9hp, perfect for recreational small and medium sized boats such as sailboats and some motor boats.

1.1 In the Package

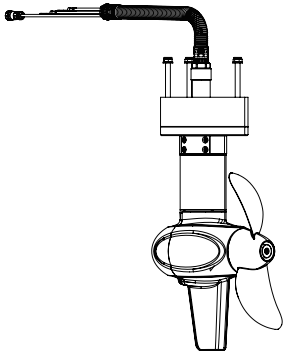
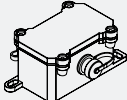
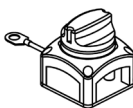
When you receive a set of Pod Drive Evo, unpack its package and check if all the items below are included in the package. If there is any loss or transport damage, please contact your dealer immediately.

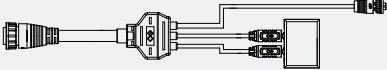
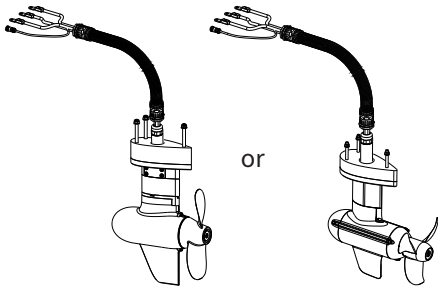
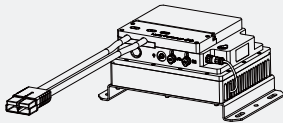
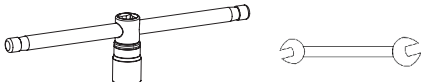
| Items | Qty./Unit | Figure |
|--------------------------|-----------|---|
| Pod Drive 1.0 Evo | | |
| Pod Motor | 1 Set |  |
| Communication Module | 1 Set |  |
| Power Switch | 1 Set |  |

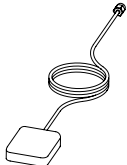
| Items | Qty./Unit | Figure |
|---|-----------|---|
| Connection Cable for Pod 1.0 Evo and Spirit Battery Plus (Purchased separately) | 1 Set |  |
| Pod Drive 3.0 Evo & Pod Drive 6.0 Evo | | |
| Pod Motor | 1 Set |  |
| Driver Module | 1 Set |  |
| Wrench Set | 1 Set |  |
| Main Switch Cable | 1 Set |  |
| External GPS Antenna | 1 Set |  |

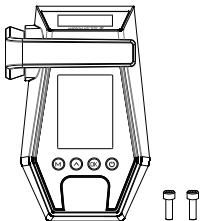
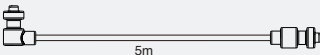
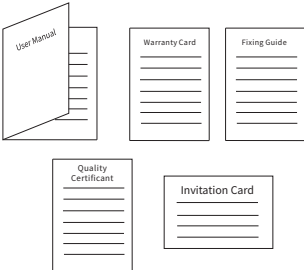
| Items | Qty./Unit | Figure |
|---|-----------|---|
| Shared by Pod Drive Evo | | |
| Evo Remote Control (Purchased separately) | 1 Set |  |
| Communication Cable | 1 Set |  |
| User Manual, Fixing Guide, Warranty Card, Invitation Card & Quality Certificate | 1 Set |  |



The Evo Remote Control need to be purchased separately.



Other accessories such as batteries, charger, etc. appearing in this manual but not included in this package list require users to purchase them from ePropulsion authorized dealers.



Save ePropulsion original package for transport and storage.

1.2 Parts and Diagrams

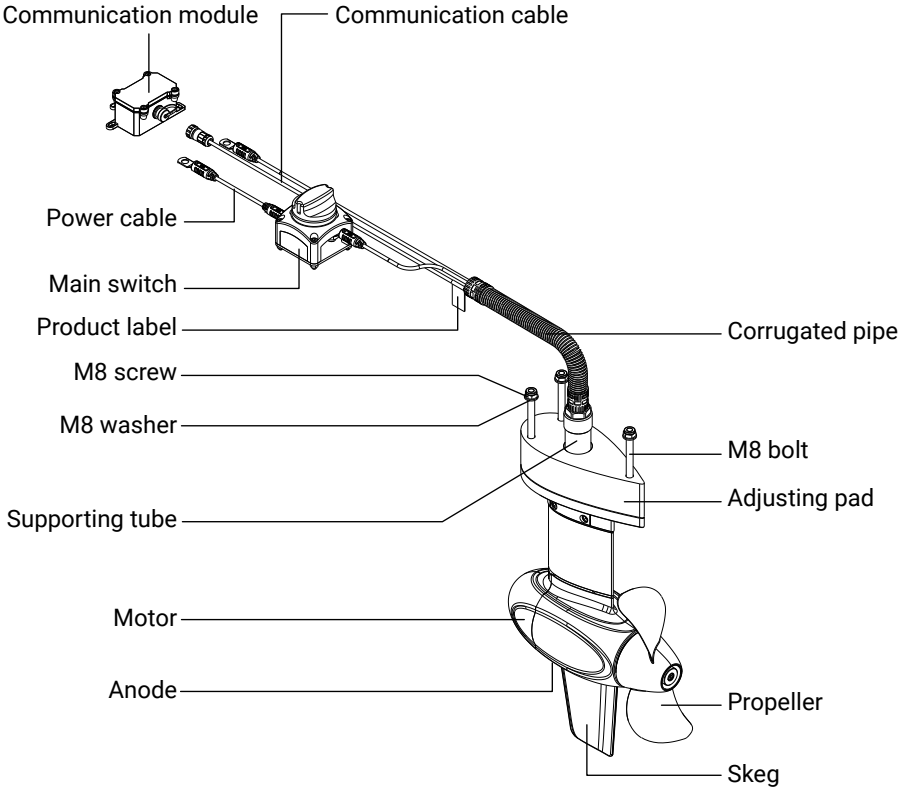

Figure 1-1 Pod Drive 1.0 Evo

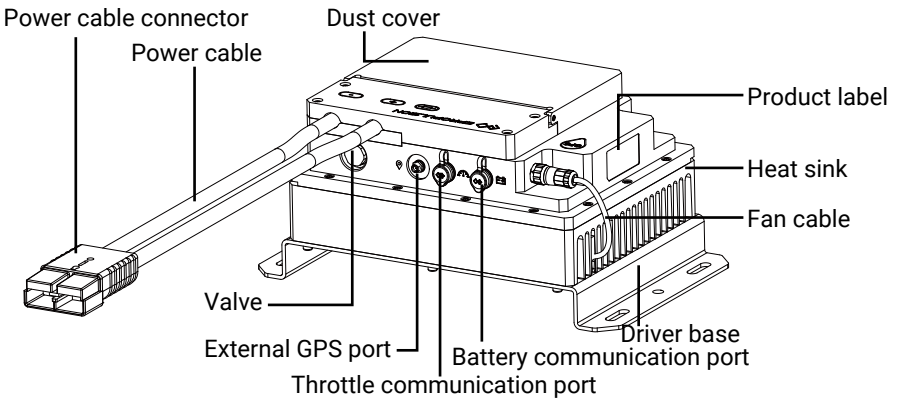

Figure 1-2 Pod Drive 3.0 Evo & Pod Drive 6.0 Evo Driver

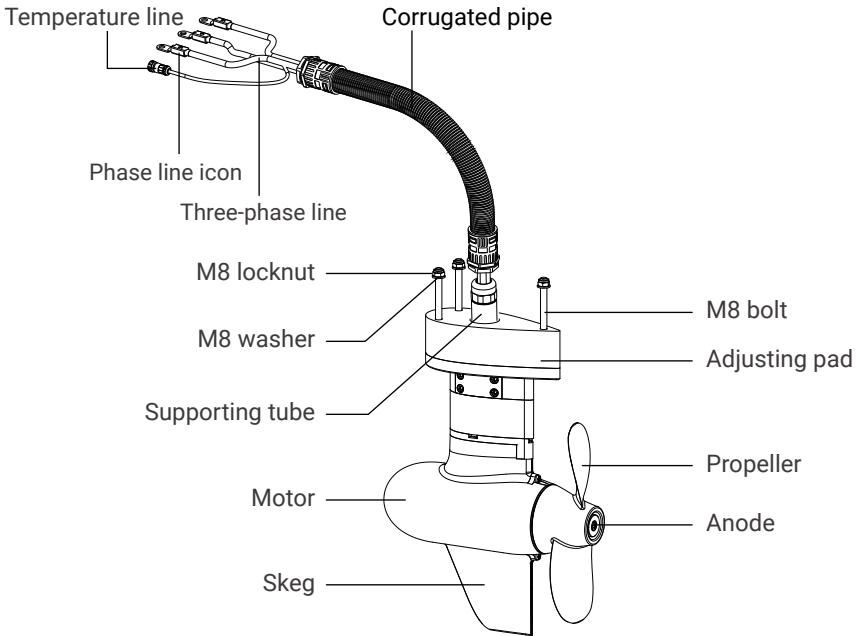

Figure 1-3 Pod Drive 3.0 Evo

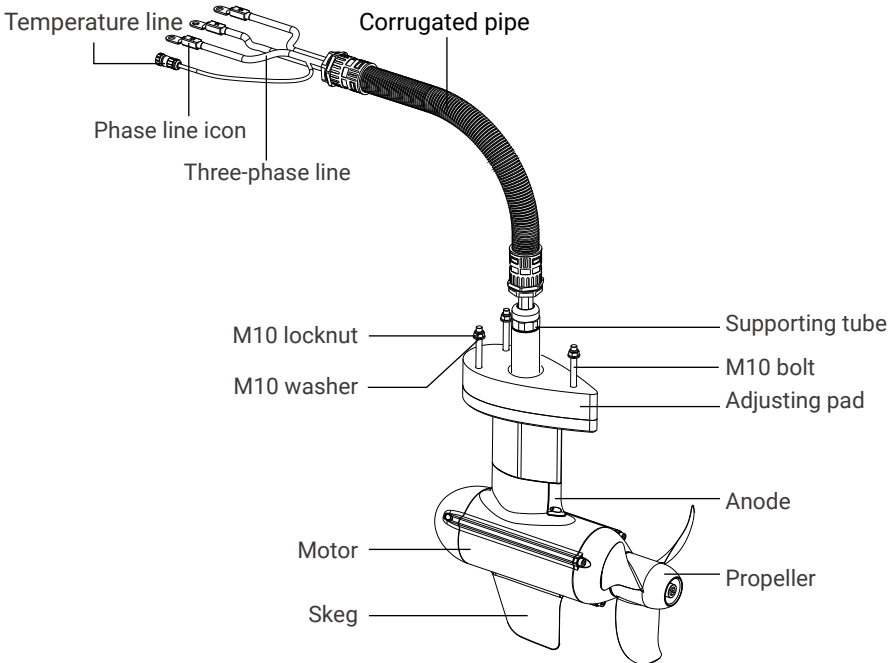

Figure 1-4 Pod Drive 6.0 Evo

1.3 Technical Data

| | Pod Drive 1.0 Evo | Pod Drive 3.0 Evo | Pod Drive 6.0 Evo |
|------------------------------|---|---|--|
| Type | Electric Pod Drive Motor | | |
| Input Power | 1 kW | 3 kW | 6 kW |
| Rated Voltage | 48V | | |
| Equivalent Power | 3 hp | 6 hp | 9.9 hp |
| Max Overall Efficiency | 55% | 51% | 57% |
| Rated Rotation Speed | 1200 rpm | 2300 rpm | 1500 rpm |
| Control System | Evo Remote Control / Evo Side Mount Control / Evo Dual Remote Control | | |
| Weight | 6.2 kg / 13.7 lbs | 15.3 kg / 33.7 lbs | 31kg / 68.3 lbs |
| Propeller (Diameter × Pitch) | 11" × 5.8" composite propeller, two-blade | 10.2" × 6.7" composite propeller, two-blade | 12.6" × 8.7" aluminum propeller, three-blade |

| External Battery Requirement | |
|--------------------------------------|--------------------------------------|
| Type | Lead-acid Battery or Lithium Battery |
| Rated Voltage | 48 V |
| Minimum Voltage | 39 V |
| Maximum Voltage | 60 V |
| Minimum Continuous Discharge Current | 28 A |
| Internal Resistance | <100 mΩ |

1.4 Declaration of Conformity

Object of the Declaration:

Product: Electric Outboard Motor

Model: Pod Drive 1.0 Evo, Pod Drive 3.0 Evo, Pod Drive 6.0 Evo

Company Name: Guangdong ePropulsion Technology Limited

Address: Room 201, Bldg.17A, 4th XinZhu Road, SongShan Lake District, Dongguan City, Guangdong Province, China

The object of the declaration is in conformity with the following directives:

| | |
|---------------|------------|
| EMC-directive | 2014/30/EU |
| MD-directive | 2006/42/EC |
| RED-directive | 2014/53/EU |

Applied Standards:

| | |
|---------------------------|-------------------------|
| EN 55014-1:2017 | EN 300328:2019 |
| EN 55014-2:2015 | EN 50663:2017 |
| EN 61000-3-2:2014 | EN 62368-1:2014+A1:2017 |
| EN 61000-3-3:2013/A1:2019 | EN 60204-1:2018 |
| EN 301489-1:2019 | EN ISO 12100:2010 |
| EN 301489-3:2019 | |

This device complies with part 15 of the FCC Rules: Operation is subject to the following two conditions:

1. This device may not cause harmful interference and,
2. This device must accept any interference received, including interference that may cause undesired operation.

Signature: 

Shizheng Tao, Chief Executive Officer & Cofounder of
Guangdong ePropulsion Technology Limited

1.5 Important Notes

1. When choosing wireless remote control, ensure the top of the communication module/driver module is uncovered to avoid wireless signal attenuation.
2. Only adults who have fully read and understood this manual are allowed to operate this product. Read the full user manual carefully before operation, ePropulsion accepts no liability for any damage or malfunction caused by operations violating this manual.
3. Only boat owners who are familiar with their boats are allowed to use this pod system. For a newly bought boat, the boat owner should learn all aspects of the boat including how the boat behaves in different conditions and practicing controlling the boat before mounting and operating this pod system.
4. Before operation, familiarize yourself with all the functions and operations of this product. If there is more than one person onboard, make sure you are not the only one onboard who knows how to operate this pod drive system to help in case of an unforeseen emergency.
5. Follow boat builder's instructions to mount this product to your boat. It is suggested to have certified boat builders or professional installers to install this pod system to your boat. Never try to install the pod system on your own if you never have experience of mounting a pod to your boat before.
6. Check the weather before operation.
7. Watch the environment before operation. The rotating blades of pod drives are very dangerous and will hurt people or creatures. Do not operate the pod drive in areas with swimmers or bathers around.
8. If the pod drive system is the only power source of your boat, make sure batteries on board have enough power for your round trip. We recommend you to calculate distance and battery consumption.
9. Check before each trip if there are enough safety equipment including but not limited to enough life jackets, personal flotation devices, fire extinguishers, bells and whistles, communication equipment, and paddles, etc. Check available local boating safety requirement before operating.
10. If the pod drive strikes other objects in the water, please stop running immediately. Return to the nearest harbor and find your dealer for assistance.
11. If an error code displays and the pod drive malfunctions, please reset the throttle to zero position and cut the power off, then refer to the Warning Information to acquire the solution to the error.
12. Stop the pod drive immediately if someone falls into water.
13. Only run the pod drive while the propeller is under water.

2 Checking the Propeller

Before use, check the propeller and if necessary, eg. the original propeller is broken, change a new propeller.

Follow instructions in Figure 2-1~2-3 to assemble a propeller properly.

Assemble a propeller for Pod Drive1.0 Evo:

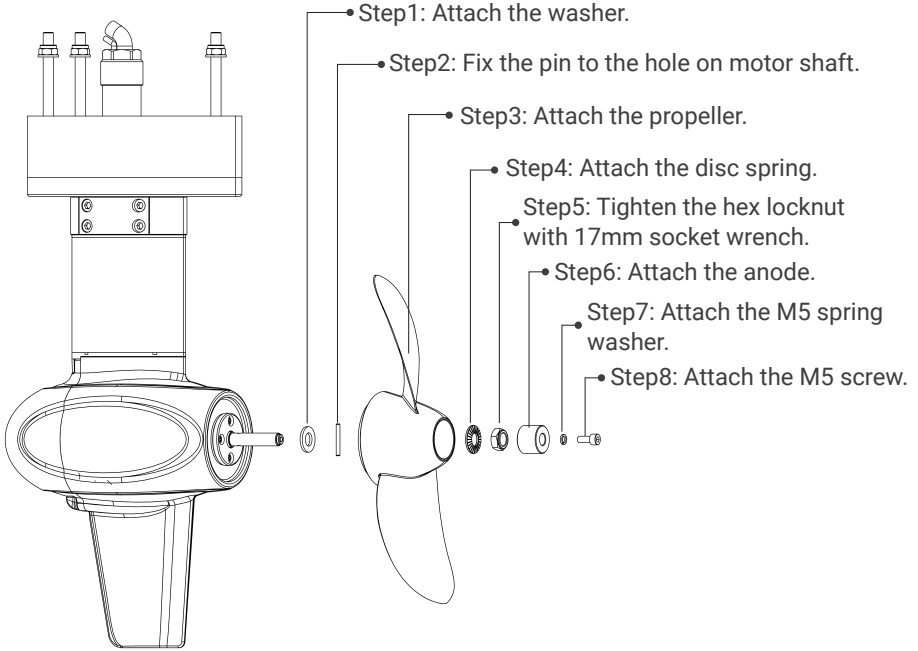

Figure 2-1

Assemble a propeller for Pod Drive3.0 Evo:

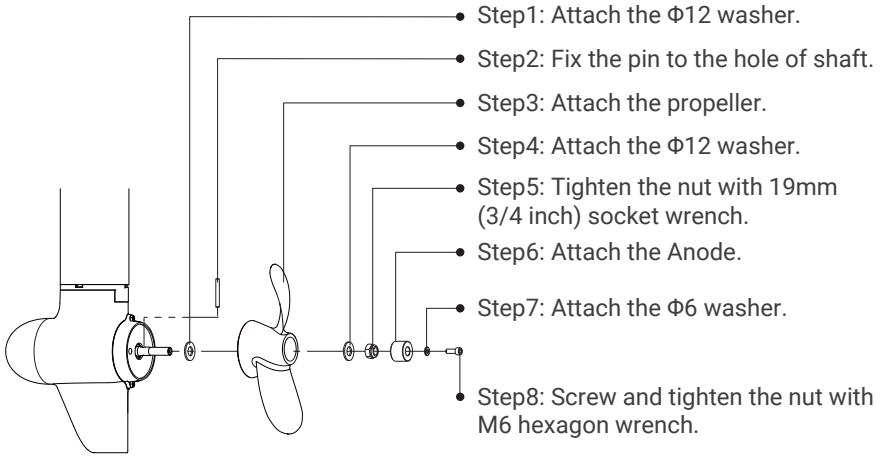

Figure 2-2

Assemble a propeller for Pod Drive 6.0 Evo:

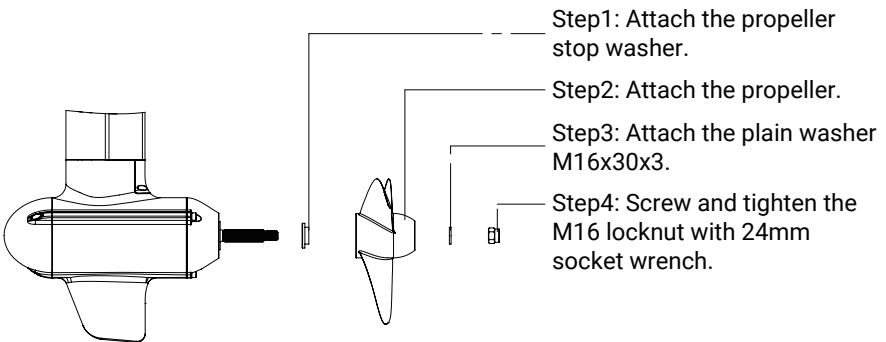

Figure 2-3

3 Mounting the Motor

Mounting Position

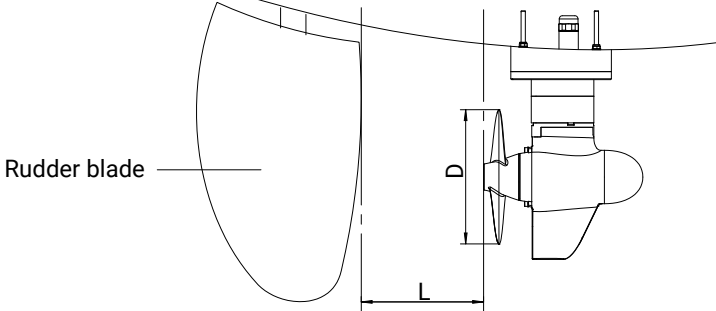

Figure 3-1

Recommended mounting position for all kinds of boats:

$$D/2 \leq L \leq 2D$$

Step 1: Drill four holes in the proper position through the hull bottom. The suggested dimensions of the four holes are shown below (please refer to the fixing guide):

Pod Drive1.0 Evo:

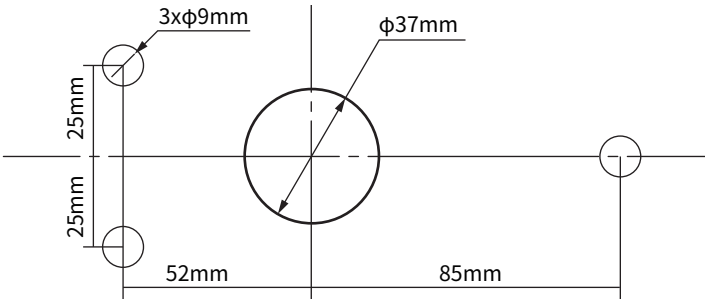

Figure 3-2

Pod Drive3.0 Evo:

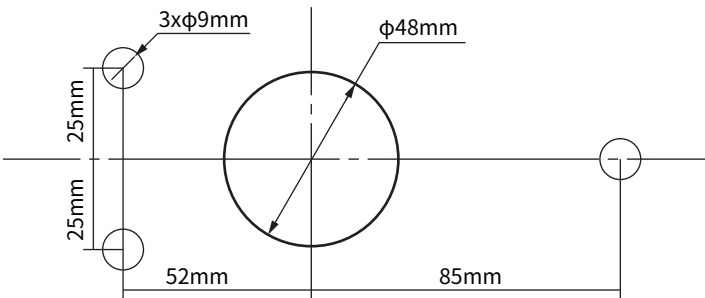

Figure 3-3

Pod Drive6.0 Evo:

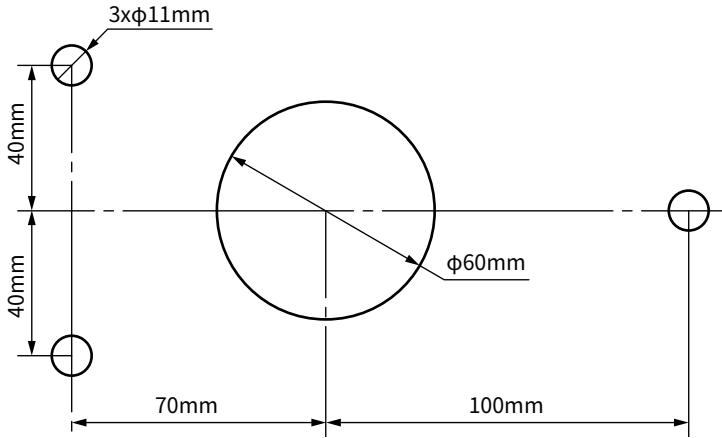

Figure 3-4

Step 2: Grind the adjustment pad by using an angle grinder until it fits the bottom of the boat where it is installed as much as possible, and install it on the mounting plate (Note: the machined side of the adjustment pad is facing up).

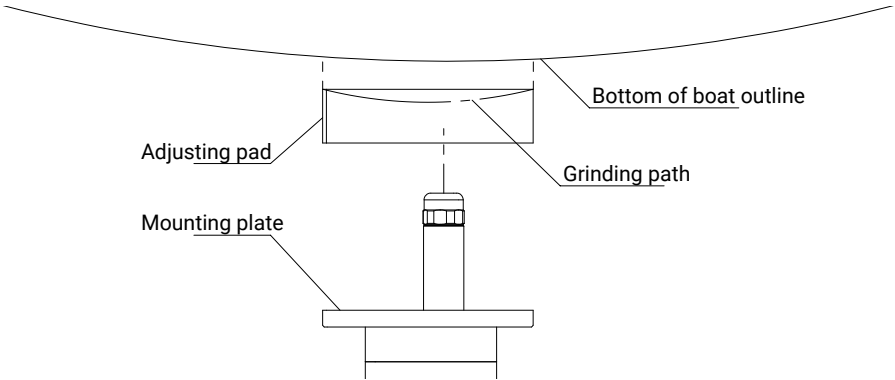



Figure 3-5

Step 3: Hold the Pod Motor and mount its three bolts (M8 for Pod Drive 1.0 Evo and Pod Drive 3.0 Evo, M10 for Pod Drive 6.0 Evo), bellows (with three-phase wires inside), and support tube to the bottom of boat according to the 4 holes machined in step 1.

 When mounting the motor, it is necessary to support the ship with a frame, which is more convenient for mounting and positioning.

- 💡 Please ensure that when mounting the motor support pipe through the bottom of the boat, ensure that the position of the gland head is inside the bottom of the ship. Make sure to apply sealant to the positioning hole to prevent water from entering the motor.

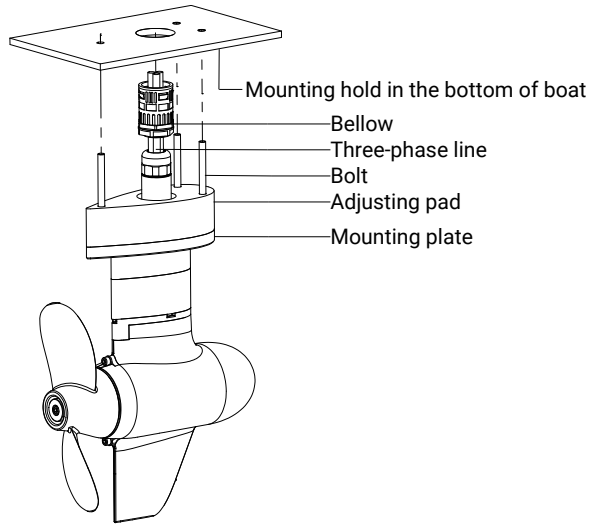

Figure 3-6

Step 4: Put the washer and nut on the bolt, and use the hexagon wrench to tighten the three locknuts, so that the motor can be fastened to the bottom of the boat. Salt water sealant to ensure that there will be no leakage from the mounting holes in the bottom of the boat.

- 💡 Make sure that the motor's mounting fasteners are securely installed, as loose fasteners may cause the motor to fall into water or be damaged. Fasteners should be inspected before each use as they may loosen due to mechanical vibration.

- 💡 It is recommended to use a cable or chain to tie the shaft to prevent the motor from falling off the bottom of the boat and cannot be retrieved. Attach the cable to the support tube and to a firm anchor point on the boat.

- 💡 There will be some water flowing out after the machine is taken out of the water as the inside of the support tube is empty.

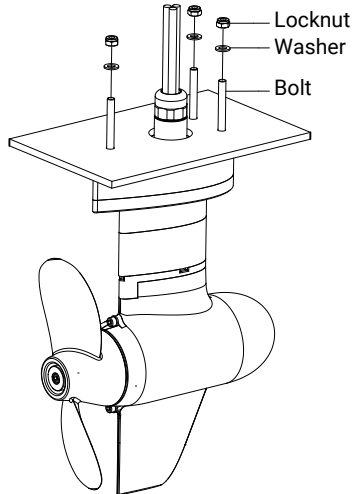

Figure 3-7

Pod Drive 1.0 Evo:

Step 5: Place the communication module on the proper position on the board and fix it with M4 screws.

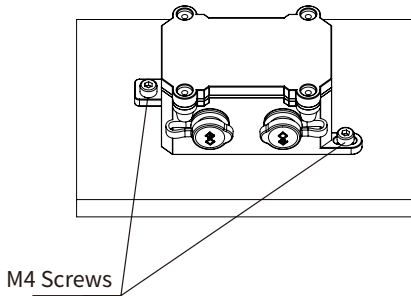

Figure 3-8

Step 6: Connect the power switch to the positive pole (red line) of the power cable of Pod Drive1.0 Evo.

Pod Drive 3.0 & 6.0 Evo:

Step 5: Check the three phase lines U-U1, V-V1, W-W1, put the three phase lines into the phase line clamp; fix the terminal on the driver with the hexagon screw M10 and washer (tightening torque 8 -10Nm); finally insert the temperature line into the corresponding connector and tighten it.

⚠ Please check the U V W connection is correct, otherwise it may cause the motor to reverse.

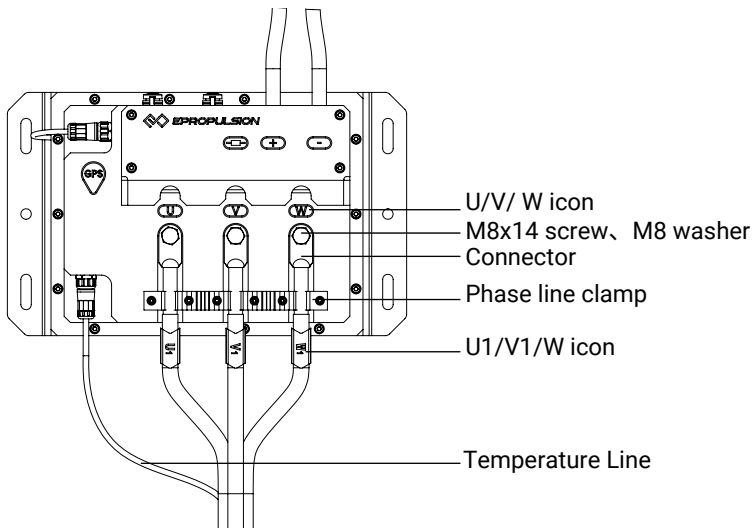

Figure 3-9

Step 6: Place the driver module on the proper position on the board and fix it with M8 screws (refer to figure 3-8 for the fixing holes).

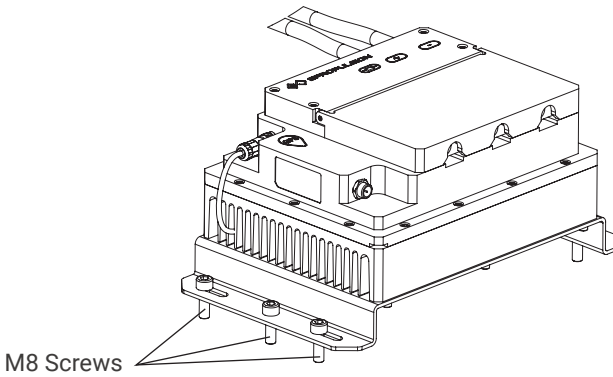

Figure 3-10

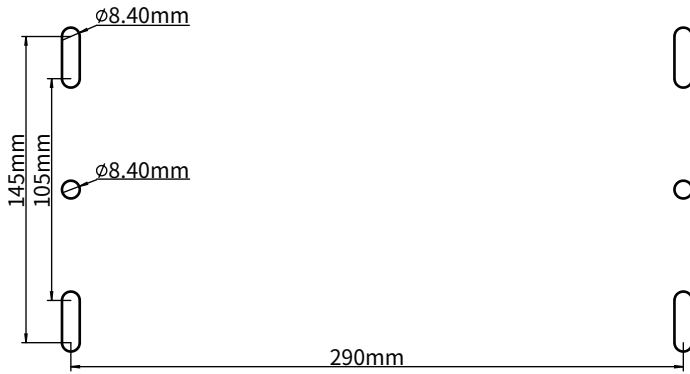

Figure 3-11

💡 More than 120mm space should be reserved around the driver for air flow.

4 Connecting the Battery

4.1 Connecting the E Battery

Before connecting to a battery, make sure the main switch is off, and fix the battery and communication module/driver on the boat.

1. Connect the power cable of the pod drive to the battery.
2. Connect the E battery and pod drive with a communication cable.
3. Connect the control system and pod drive with a communication cable.

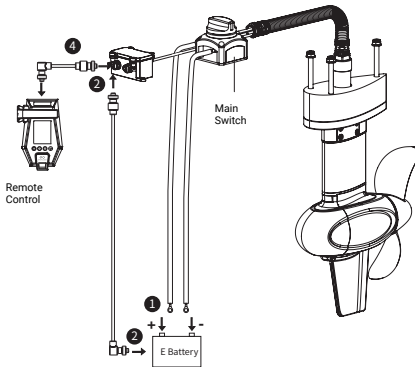

Figure 4-1

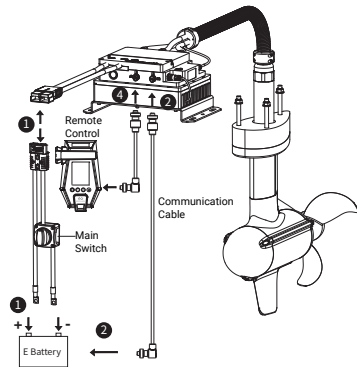

Figure 4-2

- ⚠️ Avoid battery short-circuit during connection.
- ⚠️ Do not short-circuit the main switch with other power supplies. The main switch should be mounted on the boat, and the back plate of the main switch should not be removed. Do not expose the main switch as it is not waterproof.
- ⚠️ Outboard motor will stop working once the power cable disconnects.
- 💡 Turn on the main switch to power on the battery before use.
- 💡 Users can also enlarge the battery capacity by connecting multiple batteries in parallel.
- 💡 The main switch and power cable are connected by the fixing screws that may loosen after long-time use. Loosen screws will lead to poor contact, which may result in overcurrent or other errors. If this problem is discovered, open the back cover of the switch, and tighten the screws inside.

4.2 Connecting a 48V Battery

Before connecting to a battery, make sure the main switch is off, and fix the battery and communication module/driver on the boat.

1. Connect the power cable of the pod drive to the battery.
2. Connect the E battery and pod drive with a communication cable.

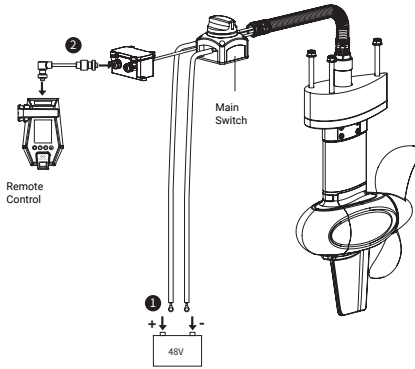

Figure 4-3

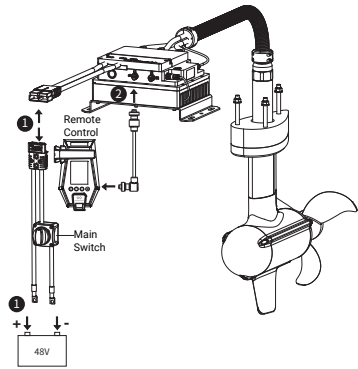

Figure 4-4

- ⚠️ Avoid battery short-circuit during connection.
- ⚠️ Do not short-circuit the main switch with other power supplies. The main switch should be mounted on the boat, and the back plate of the main switch should not be removed. Do not expose the main switch as it is not waterproof.
- ⚠️ Outboard motor will stop working once the power cable disconnects.
- 💡 Turn on the main switch to power on the battery before use.
- 💡 Users can also enlarge the battery capacity by connecting multiple batteries in parallel.
- 💡 The main switch and power cable are connected by the fixing screws that may loosen after long-time use. Loosen screws will lead to poor contact, which may result in overcurrent or other errors. If this problem is discovered, open the back cover of the switch, and tighten the screws inside.

4.3 Connecting a SPIRIT Battery Plus (Only for Pod Drive 1.0 Evo)

If you use the Pod Drive 1.0 Evo and SPIRIT Battery Plus at the same time, please follow the steps below to connect SPIRIT Battery Plus and the communication module of Pod Drive 1.0 Evo:

1. Before connecting the battery and communication module, please fix the battery and communication module on the boat.
2. Connect the connection cable for Pod 1.0 Evo and Spirit Battery Plus (purchased separately) to the power cable of the machine.
3. Insert the power cable connector into the battery discharge connector, insert the communication cable connector into the connector of the communication module (as shown in the figure below), and then tighten the connector.

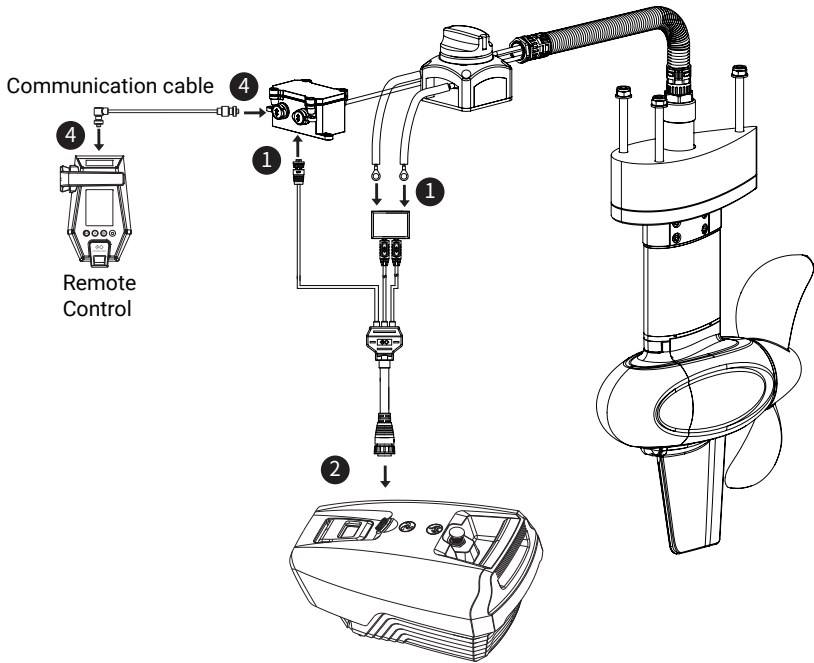

Figure 4-5

⚠ Do not short-circuit the main switch with other power supplies. The main switch should be mounted on the boat, and the back plate of the main switch should not be removed.

5 Evo Remote Control

5.1 Display Panel

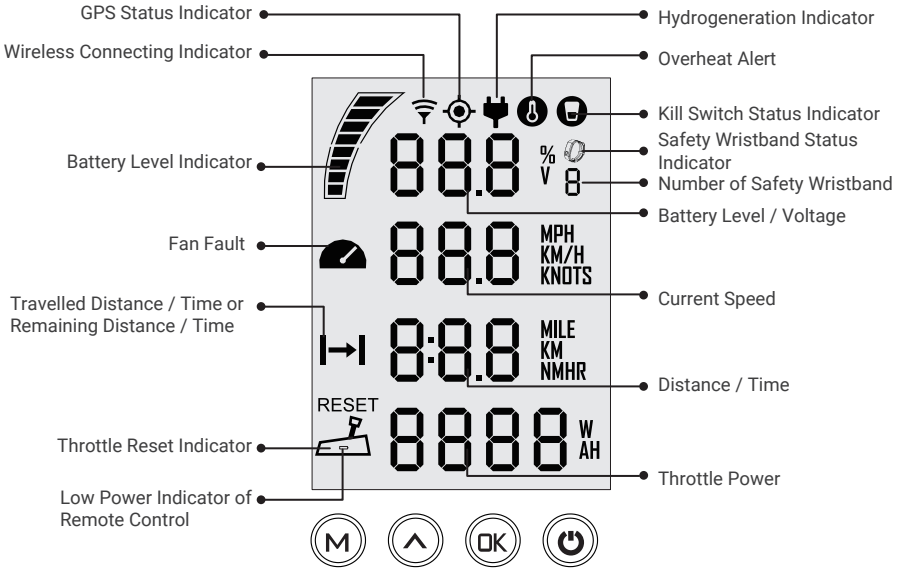



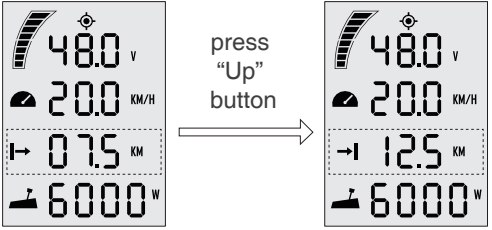
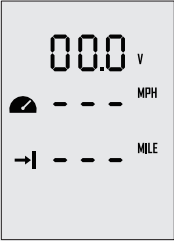





























Figure 5-1

| Buttons | Functions |
|---|--|
|  "Power" | <ol style="list-style-type: none"> 1. In power-off state, press and hold the power button to power on the remote control. 2. In power-on state, press and hold the power button to power off the remote control. |
|  "OK" | <ol style="list-style-type: none"> 1. On setting pages, press "OK" button to save the current settings and switch to the next item. 2. On setting pages, press and hold "OK" button, and the system will save your settings, the display will exit from setting page and return to the home page. 3. If home page displays or all characters display on the page, press "OK" button and hold 5s to enter the pairing page. 4. On home page, press "OK" button to switch between voltage V and battery percentage %. |

| Buttons | Functions |
|--|---|
| <p style="text-align: center;">  "Up" </p> | <ol style="list-style-type: none"> 1. On any setting page, press " ^ " button to view options for current setting. 2. In power-on state, when home page displays, press " ^ " button and hold 10s to enter the throttle calibration page. 3. On home page, press " ^ " button to switch the travelling distance or time displaying icon between " → " and " → ". <div style="text-align: center; margin-top: 20px;">  </div> <div style="display: flex; justify-content: space-around; margin-top: 10px;"> <div style="text-align: center;">Main page 1</div> <div style="text-align: center;">Main page 2</div> </div> |
| <p style="text-align: center; font-size: 2em;">M</p> <p style="text-align: center;">"Menu"</p> | <ol style="list-style-type: none"> 1. In power-on state, press and hold " M " button to enter the preference setting page. <div style="text-align: center; margin-top: 20px;">  </div> <p style="text-align: center;">Preference setting page</p> <ol style="list-style-type: none"> 2. On preference setting page, press and hold " M " button to enter the battery setting page. <div style="text-align: center; margin-top: 20px;">  </div> <p style="text-align: center;">Battery setting page</p> <ol style="list-style-type: none"> 3. On any page, press " M " button to return home page. |

 If users enter the page without setting any parameters, the current parameters displayed on the page will be saved as user parameters by default.

| Icons | Functions | |
|---|------------------------------|--|
|  | Battery level indicator | Indicating approximate battery level. The solid blocks stand for remaining battery. |
|  | Battery level/voltage | Indicating accurate current battery level percentage/battery voltage, is configurable in preference setting page. For example: 100%: indicates current battery level. 48.0 v: indicates current battery voltage. |
|  | GPS status indicator | <ul style="list-style-type: none">  Hidden: no satellite signal is received or GPS does not work.  Blink: GPS is connecting to satellites. Shown constantly: GPS is in use. |
|  | Over-heat alert | <ul style="list-style-type: none">  Hidden: system temperature is in normal range.  Blink: system temperature is a little high and the maximum input power of motor has been lowered  Shown constantly: system is over temperature and the pod will stop working. The pod can't be started until the system temperature drops to a certain level. |
|  | Kill switch status indicator | <ul style="list-style-type: none">  Hidden: kill switch is present and is working well.  Shown constantly: the kill switch is detached. |
|  | Current speed | Displaying real time cruising speed. Set units (KM/H, MPH or KNOTS) in preference setting page. |

| Icons | Functions | |
|---|--|--|
|  | Motor fan fault |  Blink: The motor fan has faults. Please contact the dealer to check the fan wiring. |
|  | Distance/time display | Displaying real time travel distance/time. Set units (MILE, KM (kilometer) and NM (nautical mile)) in preference setting page. The time unit is HR (hour). |
|  | Travelled distance/time or remaining distance/time | → : Remaining distance or time that the pod system can travel. Set units (MILE, KM (kilometer) and NM (nautical mile)) in preference setting page. →: Travelled distance or time. |
|  | Throttle Power | Displaying real time input power to the system. A blinking "RESET" indicating the throttle should be reset to zero position. |
|  | Wireless connecting indicator | Displaying the remote control is wireless connecting with pod drive. |
|  | Hydro generation indicator |  Shown constantly: the hydro generation function is open.  Blink: the machine is charging the battery. |
|  | Safety wristband connecting display |  Shown constantly: the safety is connecting with the remote control successfully.  Blink: there is a safety wristband to disconnect. The number indicates the number of safety wristbands connected to the remote control. |

5.2 Charging

The remote control has an in-built lithium battery for power supply. The battery will be charged automatically under normal use: get charged by solar power or wired connection.

5.2.1 Charging by Solar Power

When the solar panel receives enough sunshine, it will generate electricity to charge the in-built lithium battery.

 Face the solar panel of the remote control toward sunlight to get better charging effect.

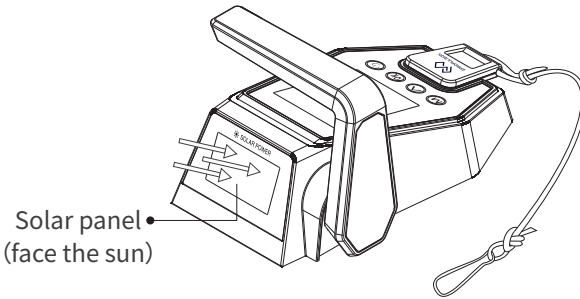



Figure 5-2

 Charging by solar power is recommended.

5.2.2 Charging by Wired Connection

If the remote control can't get enough solar power for a long time, the battery will run out. In this case, error code E60 (Figure 5-3) will display to remind you to charge the remote control.

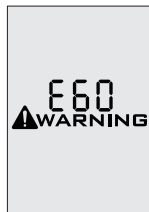



Figure 5-3

In this case, charging by wired connection is faster.

Use a communication cable to connect the remote control and the communication module/driver. Then make sure the system battery is well connected to the pod drive and powered on.

 During long-term storage, ensure to charge the remote control every 6 months to avoid over-discharge.

 Do not short-circuit the main switch with other power supplies. The main switch should be mounted on the boat, and the back plate of the main switch should not be removed.

 After long-term storage, charge the remote control before use.

 The communication cable is not included in this package. Please purchase one from your dealer if you choose this charging method. Once the communication cable disconnects, charging automatically stops and the running motor stops. Please restart the motor.

5.3 Power Adjusting

5.3.1 Power Adjusting for Evo Remote Control

 Please place the kill switch on the Evo remote control before operation.

The Evo Remote Control is mainly used to adjust the input power of the motor. When the battery is well connected and switched on, power on the Remote Control to start the pod drive, then slowly push the throttle forward position to increase the power. The maximum forward/backward power is shown below.

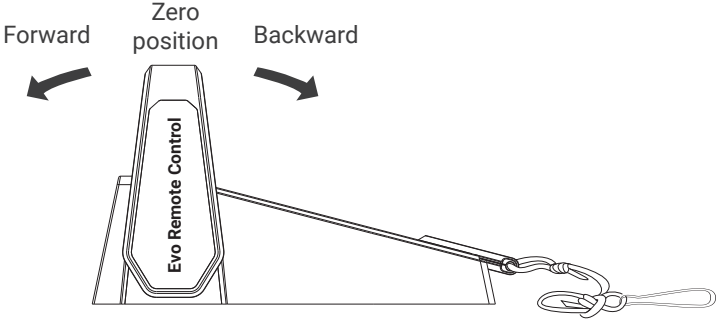





Figure 5-4

| Model | Max forward power | Max backward power |
|------------------|-------------------|--------------------|
| Pod Drive1.0 Evo | 1 kW | 1 kW |
| Pod Drive3.0 Evo | 3 kW | 3 kW |
| Pod Drive6.0 Evo | 6 kW | 6 kW |

 Before power on the Remote Control, please reset the throttle to neutral position.

 If you find a blinking "RESET" on the display panel, you are reminded to reset the throttle to neutral position.

 If you pull the throttle from the forward position to the backward position directly, the motor will first stop shortly, then start turning to the reverse direction.

5.3.2 Recalibration

If the error code displays as the figure 5-6, users should calibrate the throttle **strictly** as below steps.



 Before calibration, please detach the kill switch from the control system.



Figure 5-5

| Recalibration process | LCD Displaying |
|--|---|
| <p>Step1: Long press "^" button for 10s until "CAL FO" displays.</p> |  |
| <p>Step2: Push the throttle to the maximum forward power position, then press "OK" button. "CAL 5t" will display and "CAL" will be blinking.</p> |  |
| <p>Step3: Pull the throttle to the middle (zero) position where you can hear a click sound, then press "OK" button, "CAL bA" will display and "CAL" will be blinking.</p> |  |
| <p>Step4: Pull the throttle to the maximum backward power position, then press "OK" button. It will return to the main page automatically.</p> | |

5.4 Use of Kill Switch

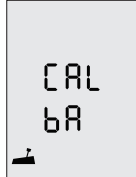
- Attach the kill switch and tie its lanyard to your wrist or life jacket.
- Stop the pod drive in emergency by detaching the kill switch.
- To run the motor again, first attach the kill switch then start the motor.

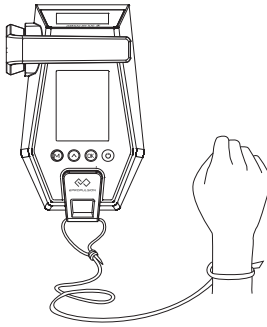

Figure 5-6

- ⚠ The kill switch generates magnetic field. Keep it 50cm / 20inches away from medical implants like pacemakers and magnetic cards (e.g. credit card) as well as other magnetic media.
- ⚠ The magnetic field of the kill switch may interfere with some electronic instruments. Keep it away from these electronic instruments.

5.5 Use of Safety Wristband

5.5.1 Pairing Safety Wristband with Remote Control

Press the "▲" and "OK" buttons and hold for a while to display the safety wristband icon and "SE". At this time, approach the safety wristband that needs to be paired, turn on the safety wristband, and the remote control displays the "SUC", indicating successfully pairing. Keep in this interface and continue to press "OK" to pair the safety wristband continuously (the maximum number of pairs is 8). After completing the pairing, press the "M" button to return to the main page.

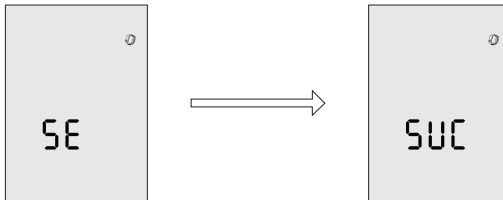



Figure 5-7

5.5.2 Man Overboard Protection

After the safety wristband and the remote control are paired, when the safety wristband falls into the water and the remote control is on, the remote control display will flash with a buzzing sound. The safety wristband icon flashes and the number of safety wristband decreases. At this time, you can continue to operate the machine by returning the throttle to zero position. The buzzer of the remote control will stop, but the display continues to flash. If you confirm that you need to cancel the alarm state, please restart the remote control or the disconnected wristband reconnects.

5.5.3 Emergency Stop

After the safety wristband and the remote control are paired, when the remote control is in operation, short press the button of the safety wristband, the display of the remote control will flash with a buzzer. At the same time, the safety wristband icon flashes and the number of safety wristband displayed at the bottom decreases. At this time, you can continue to operate the machine by returning the throttle to zero position. The buzzer of the remote control stops, but the display continues to flash. If you confirm that you need to cancel the alarm state, please restart the remote control or short press the safety wristband after 5 seconds.

 When a wristband is disconnected or an emergency stop is performed, the stop command of other wristbands will not work until it returns to the normal state.

5.6 Pairing Remote Control with the Pod Drive

Before use please pair remote control with the pod drive. There are two methods to pair the remote control. Please choose one of the two methods and follow the steps to build new communication.

Method 1. Pairing without Communication Cable

 Because the mounting place of the pod drive will cause the poor signal, it is not recommended to use wireless pairing.

Step1: Switch off system power and hold the remote control within 0.5m of the communication module/driver module.

Step2: Press and hold the “” button to switch on the remote control.

Step3: Ensure the wireless indicator is shown constantly on the home page.

Step4: Press “OK” button and hold 5s to enter the pairing setting page (Figure 5-8).

On this page, you can find the blinking “Add” and “RUF”, and a countdown timer “060” (60s).



Figure 5-8

Step5: Switch on system power. Wait for them to get paired in seconds.

Step6: After pairing, the LCD panel will display as Figure 5-9 for 5s, then returning to home page automatically.

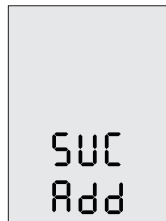

Figure 5-9

💡 If pairing fails within 60s, go back to **Step3** and try again.

Method 2. Pairing with Communication Cable

Step1: Switch off system power and the remote control.

Step2: Connect the remote control and the Communication module with a communication cable.

Step3: Switch on system power and the remote control. Wait for them to get paired in seconds. Pairing succeeds when home page displays.

💡 No matter it is in wireless communication status or not, it will switch to wired communication status when you are pairing with a communication cable.

💡 If the control system or the pod drive is replaced with a new one, the original wireless link will break and wireless communication failure will occur. The main page of the LCD panel on the Remote Control will display as below. In this case, users should conduct pairing again.

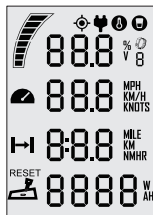

Figure 5-10

However, if the Remote Control and the pod drive are not replaced, but the LCD panel still displays like this, you should check and:

- 1) Make sure the Remote Control is not far from the outboard motor;
- 2) Make sure all the equipment involved is normally powered on.

If the Remote Control still displays like Figure 5-10 after check, it indicates an error has occurred. Please contact your dealer for repair.

5.7 Warning Messages

When the pod drive motor is running in abnormal conditions or out of order, a warning message with an error code will display on the LCD panel. Figure 5-12 is an example.

Please find more error codes and corresponding solutions in the below table.



Figure 5-11

| Code | Cause | Solution |
|------|--|---|
| E01 | Battery voltage beyond operation range. | Replace a battery based on suggested operation specifications. |
| E02 | Propeller may be blocked, causing motor overcurrent | Refer to Solution to E10. |
| | Motor fails or circuit board fails causing motor overcurrent | Try to turn off the main switch and wait for 10 seconds then turn on the switch again. |
| E06 | The battery voltage level is too low. | Operate the motor at low power. Please charge the battery as soon as possible. |
| E10 | Motor stall, which may be caused by blocked propeller | Turn off power, then clean up the things winding around the propeller. Test if the propeller can be rotated by hand before operation. |
| E11 | The temperature of motor is too high. | Stop operating the pod drive and wait until the temperature falls within the normal operating temperature range. |

| Code | Cause | Solution |
|------------------------|--|---|
| E12 | The temperature of circuit board is too high. | Stop operating the pod drive and wait until the temperature falls within the normal operating temperature range. |
| E22 | MCU Communication Abnormality | Please restart to see if the error disappears, if not, please contact your dealer for help. |
| E30 | Throttle position sensor failure, should recalibrate the throttle position sensor. | Please refer to section 5.3.2 <i>Recalibration</i> to recalibrate the throttle position sensor. |
| E56 | Communication Error between pod drive and battery | Check if the communication cable between pod drive and battery is well connected, if yes, please restart the system. |
| E60 | The remote control is running out of power. | Please connect the remote control to the pod by a communication cable. Please refer to section 5.2.2 <i>Charged by Wired Connection</i> . |
| All characters display | The motor has no power. | Connect the battery to the pod drive and then turn on the main switch. |
| | Not paired | Please refer to section 5.6 <i>Pairing Remote Control with the Pod Drive</i> . |

 If the problem persists, please consult your ePropulsion authorized dealer for assistance.

6 Configurations

6.1 Preference Settings

It's advised to set display preference by these steps before operation.

Step1: In power-on state, press “M” button and hold to enter the preference setting page as shown in Figure 6-1. Users can choose display items based on personal needs and preference.

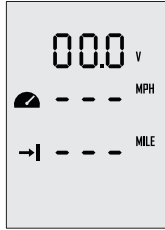

Figure 6-1

Step2: On the preference setting page, the blinking item is the object waiting to be set. Press the “^” button to view options for the blinking item. For example, in Figure 6-1, if “V” is blinking on the preference setting page, it means that “V” has other alternate options. Just press the “^” button, and “V” will switch to “%”, i.e. the displayed item is switched from voltage to battery level.



Step3: Press “OK” button to save setting for the current item and skip to the next item simultaneously.

Step4: When all the items have been set well, long press the “OK” button to save all the settings and return to the main page.

6.2 Battery Configuration

Accurate battery configuration helps achieve precise estimation of the battery's discharging state. When using an ePropulsion E Series Battery, battery configuration is self-activated by the control system given that all the communication cables are well connected. When not using E Series Batteries, users should manually configure the batteries via Remote Control at the first time use, so the battery level will display more accurate.

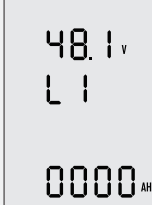
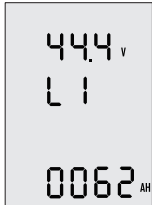
 Battery configuration should be carried out if a battery with different type/capacity/voltage is connected to Pod Evo for the first time.

| Battery Configuration Process | LCD Displaying |
|---|---|
| <p>Step1: First, turn on the main switch and the Evo Remote Control.</p> <p>Press and hold the “M” and “OK” button simultaneously to enter the battery setting page. Users can see the battery type blinking and it’s ready for configuration.</p> |  |
| <p>Step2: Press “OK” button to switch the battery type options between Pb, Li and LFE.</p> <p>Pb: Lead-acid battery Li: Lithium battery LFE: Lithium-ion ferrous phosphate battery</p> |  |
| <p>Step3: Press “^” button to save the battery type setting and return to battery nominal voltage setting.</p> <p>Voltage options are provided by battery type. Press the “OK” button to view these options and select the closest rated voltage based on the battery you use.</p> |  |
| <p>Step5: Press “^” button to save the save the current setting and move to the battery level setting.</p> <p>Press the “OK” button to select the battery capacity according to the battery you use. Please set the four-digit value from left to right in turn. After each value is set, press the “^” button to move to the next value.</p> <p>Note that the unit of capacity is “Ah”, usually the capacity of battery is expressed in “Wh”, and we can get the capacity in “Ah” by following the below formula:</p> $\text{Capacity in Ah} = \frac{\text{Capacity in Wh}}{\text{Nominal voltage in V}}$ <p>Eg. if users use a 3000Wh Lithium battery with 48.1V nominal voltage, then the battery is about 62.37Ah, so you can set 62Ah as the capacity setting.</p> |  |

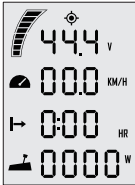
| Battery Configuration Process | LCD Displaying |
|--|---|
| <p>Step5: Press “M” button to save all the settings and return to the main page.</p> |  |

 Lithium batteries, lead acid batteries and lithium iron phosphate batteries are recommended to use with Pod Evo. Other types of battery may fail to make Pod Evo work properly.

 When you use the below batteries, please set battery type and rated voltage value based on the parameters in the following table.

| Battery type | Nominal Voltage options |
|--------------|---|
| LI | 43.2V 44.4V 45.6V 46.8V 48.1V 49.4V 50.4V 51.8V 53.2V |
| Pb | 44.0V 46.0V 48.0V 50.0V 52.0V 54.0V |
| LFE | 44.8V 48.0V 51.2V |

 Update the battery configuration is necessary if a different type of battery has been applied.

 When using non-ePropulsion batteries, before starting the outboard, users should configure the batteries via the Evo Control System for the first time use, otherwise the batteries may not work properly.

7 Checklist before Use

1. Ensure the propeller is correctly and firmly mounted on the pod drive.
2. Ensure the pod drive is correctly and firmly mounted on the boat.
3. Ensure the remote control and steering wheel are installed in proper position before turning on the power.
4. Ensure the throttle travels smoothly with no obstacles.
5. Before connecting the battery, check and make sure there is no poor contacts or defects in cables.
6. Check and ensure the main switch is able to power on and off normally. After that, turn off the main switch.
7. Ensure the battery has enough power.
8. Ensure the remote control has enough power.



Make sure the power cable is dry before connecting it to the battery or powering on the system.

8 Starting the Pod Drive

1. Complete the check list.
2. Remove the kill switch from the remote control.
3. Push the throttle to zero position.
4. Connect the battery with the pod drive.
5. If use ePropulsion battery, turn on the main switch.
6. Press "  " button to turn on the remote control.
7. Pair the remote control with the pod drive.
8. Carry out preference setting and battery configuration if necessary.
9. Tie the kill switch to your wrist or life vest, then attach the kill switch on the remote control.
10. Push the throttle slowly to start running.

9 Stopping the Pod Drive

It's recommended to stop the pod drive as the following procedures.

1. Return the throttle to zero position.
2. Wait until the motor stops, then detach the kill switch.
3. Press and hold the “” button until the remote control is switched off.
4. Turn off the main switch. If the pod drive is not connected to a SPIRIT battery, please also turn off the battery by pressing the power button.



The motor will also stop in any below situations.

1. Throttle is in zero position.
2. Kill switch is not placed in the correct position.
3. The power cable connected to the battery is loose.
4. The communication between the remote control and the pod drive is interrupted.
5. The connection between the battery and the pod drive is disconnected.
6. The system is malfunctioning (such as the motor is blocked or the battery voltage is too low).
7. The main switch is turned off.

10 Hydro Generation Function

Pod Drive Evo machines can drive the propeller to charge the battery (only the ePropulsion battery) through water flow.

The machine will enter the hydro generation state if the following conditions are met:

1. The remote control is set to turn on the hydro generation function (enabled by default).
2. The remote control is in the zero position.
3. The ePropulsion battery power is below 90%.
4. The machine will enter the hydro generation state after the boat speed is above 6km/h stably for 4 seconds.

When any of the following conditions occur, the hydro generation will be stopped:

1. The remote control is set to turn off the hydro generation function.
2. The remote control is in the forward/backward state (not in the zero position).
3. The ship is not traveling or traveling too fast (Pod Drive 1.0 Evo is higher than 35km/h, Pod Drive 3.0/6.0 Evo is higher than 45km/h).
4. The battery level is higher than 90%.



The hydro generation function can be used only when connecting ePropulsion batteries.

Set up the hydro generation function

When the Evo remote control and the machine are successfully connected, and the Evo remote control and the machine are both on. Press the "M", "▲" and "OK" buttons at the same time to enter the hydro generation setting interface. Then press "OK" to change the state of the hydro generation function (En means on, Dis means off).

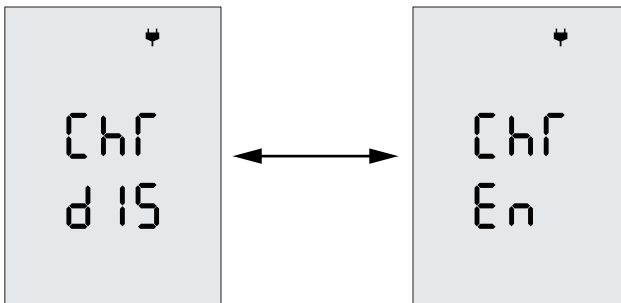



Figure 9-1

11 Maintenance

11.1 Contents and precautions of daily maintenance

1. Regularly check the use of the propeller, including whether the propeller blades are worn, cavitated or otherwise damaged, whether the pins are worn or damaged, whether the propeller is wrapped with aquatic plants, fishing nets or lines, and the degree of corrosion of the anode block.
2. Regularly check whether the fasteners installed on the bottom of the motor are loose and the sealant at the installation holes.
3. Before use, make sure that the connecting bolts of the three-phase line of the drive module are firm.

 If the motor needs to be repaired, the boat needs to be hoisted so that the motor can be easily repaired.

11.1 Propeller Maintenance

 Ensure the battery is disconnected before each check, as a rotating propeller is dangerous.

 Gloves are recommended to wear, in order to protect your hand from the sharp propeller edges.

 Regularly check whether the propeller is damaged, whether there is a fishing line entangled. The motor is out of warranty due to the fishing line causing water to enter the motor.

Check the propeller based on the following tips, then refer to the *Chapter 2 Checking the Propeller* to replace a new propeller if necessary.

1. Check the propeller blades for wear broken and other damage.
2. Check the pin for wear and damage.
3. Check for water plants, fishing net or line twine around the propeller.

11.2 Replacing the Anode

Please refer to the figure below to replace a new anode if necessary.

Replacing the anode of Pod Drive 1.0 Evo

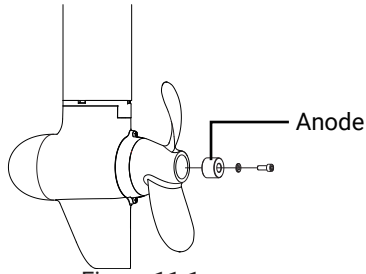

Figure 11-1

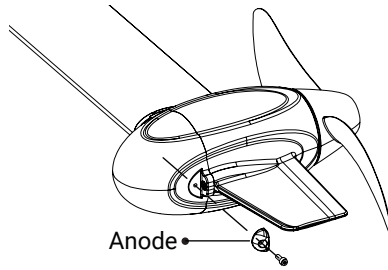

Figure 11-2

Replacing the anode of Pod Drive 3.0 Evo

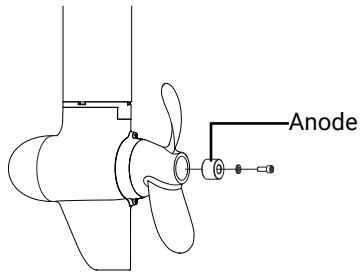

Figure 11-3

Replacing the anode of Pod Drive 6.0 Evo

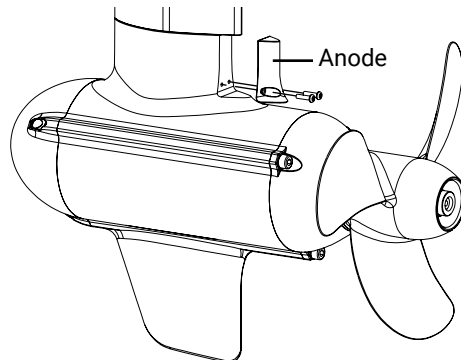

Figure 11-4 Pod 6.0 Evo with metal propeller (standard)

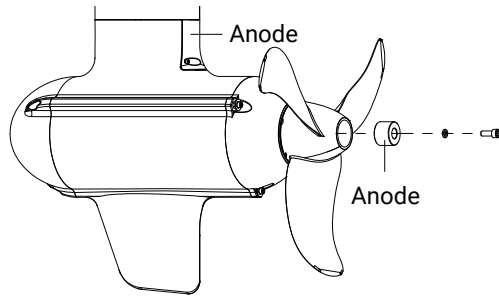

Figure 11-5 Pod 6.0 Evo with plastic propeller (optional)

11.3 Maintenance of Electrical Contacts

Clean all electrical contacts with electrical contacts cleaner every two months, and clean immediately once there is rusty show up.

12 Transport and Storage

Before long distance transport or long-term storage, please use ePropulsion original package to pack the pod drive.

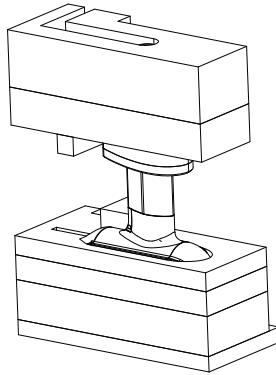



Figure 12-1

-  Make sure the pod drive gets adequate damping protection before transport and storage.
-  Store the pod drive in a well-ventilated and dry area without direct sun exposure.

12 Emergency Situations

12.1 Collision

If the pod strikes some object beneath the water, please follow below procedures.

1. Stop the pod immediately and then turn off the main switch.
2. Check the mechanical structure to see if there are damages.
3. Return to the nearest harbor or pier in low power.
4. Call your dealer to check the pod.

12.2 Low Battery Level

When the battery voltage is lower than 42V, the power will be limited by dropping voltage. When the battery voltage drops below 39V, the pod will stop automatically to prevent battery over-discharge. If this happens when the pod is far away from the shore, and there is an alternative battery, it's recommended to wait until the battery voltage rises 42V or above. When the voltage rises to a safe level, you can restart the pod system by restricting the power within 100W.

13 Warranty

Guangdong ePropulsion Technology Co., Ltd. (“ePropulsion”), China, warrants its products to be free of defects in material and workmanship under normal usage with proper installation and routine maintenance for a period of twenty-four (24) months from date of delivery of products to end customers (the “Limited Warranty Period”). The Limited Warranty is provided to the first end customer of ePropulsion products ONLY. The Customer is entitled to free repair or replacement of defective or non-conform parts. Any warranty claim must be made within six (6) months of discovery of issues as provided below.

If the Limited Warranty Period expires, you can still enjoy maintenance services from dealers/distributors authorized by ePropulsion (the “ePropulsion Service Partners”) with minimum maintenance charge per occurrence.

In all warranty cases, ePropulsion will only bear the repair cost for issued covered by the Limited Warranty only, which shall NOT include costs irrelevant such as those related to product installation, disassemble, transportation, financing, rental, etc.

Beyond the Limited Warranty, the Customer may have statutory rights in your jurisdiction according to applicable laws. Nothing in this Limited Warranty affects such rights. The Customer may have warranty claim rights arising from the purchase contract with ePropulsion Service Partners in addition to the rights granted by this Limited Warranty.

Products for commercial/professional use, even if only temporarily, are not covered by the Limited Warranty. Instead, the statutory warranty in your jurisdiction shall apply. You are encouraged to consult with ePropulsion Service Partners for applicable warranty and advice before engaging in such use.

*** Commercial/professional Use refers to application cases that have high use frequency, high-reliability requirement or aim for money making, etc.**

To keep your warranty valid, you shall follow:

- Keep the product label intact and record the Serial Number shown on the label. Never tear the label off the product. A product without the original product label is not covered by the Limited Warranty provided by ePropulsion;
- The Limited Warranty is not transferable and will not be reissued;
- The Limited Warranty may change from time to time. Pls visit our website (<http://www.epropulsion.com>) for the latest version.

Out of Warranty

ePropulsion may refuse a warranty claim if:

- Any improper operation contradicts what is written in the user manual;
- Accident, misuse, dropping, improper care or storage, willful abuse, physical damage, overcharging, over discharging, or unauthorized repair;
- Water ingress caused by external sources such as fishing nets, submerging underwater, etc;
- Product modification, alternation, disassembly, or parts/accessories attachment, which are not expressly permitted or recommended by ePropulsion;
- Failure of, or damage caused by, any 3rd party products;
- Consumables are out of warranty scope (like propeller, anode, etc.);
- Purchases of product from unauthorized dealers or seller;
- Normal wear and tear and routine servicing are excluded from the warranty;
- The product gets further damaged due to improper packing during delivery. The further damaged part will be deemed as out of warranty coverage;
- Lithium battery is classified as a UN9 hazardous item, posting and packing must be in accordance with the relevant law of the local country directive. Non-compliance may result in out of warranty coverage.

Limited Warranty Claim Procedures

The Customer shall follow the warranty claim process to make a Limited Warranty claim:

1. Contact your nearest ePropulsion Service Partners and they will provide further instruction to you if such defects are covered by the Limited Warranty or theirs.
2. Send the defective product to them together with Proof of 1st-time Purchase (e.g., receipt, invoice, etc., with information of product purchased and date of purchase), the Confirmation of Online Warranty Registration, ex-factory Serial Number, etc. Note that all labels shall be kept intact. The warranty is valid only when the information above is correct, genuine, and complete;
3. Make sure the product is properly packed during delivery, the original package is highly recommended.
4. The ePropulsion Service Partners will conduct diagnosis and examination on the

defective products to check the validity of the warranty claim.

5. If your warranty claim is accepted, the Product or its defective components/ parts will be either repaired or replaced free of charge. Note that any delivery cost incurred in the process shall be bearded by you.
6. In case your warranty claim be rejected, a repair/replace cost and fee with round trip delivery cost will be estimated and sent to you for confirmation. ePropulsion Service Partners will only begin the work after your written confirmation.



Scan to register
your product



Product
tutorial

Vielen Dank, dass Sie diese Bedienungsanleitung gelesen haben.
Wenn Sie Fragen haben oder beim Lesen Unklarheiten
aufgekommen sind, zögern Sie bitte nicht, uns zu kontaktieren.
Wir freuen uns, Ihnen behilflich sein zu können.

Thanks for reading this user manual.

If you have any concerns or find any problems while reading,
please don't hesitate to contact us. We are delighted to offer
service for you.

Guangdong ePropulsion Technology Limited

Website: www.epropulsion.com

Email: service@epropulsion.com