

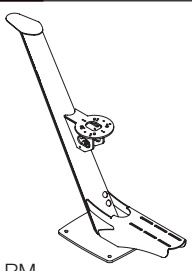
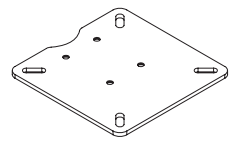
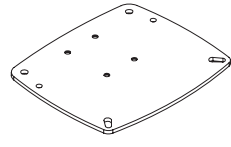
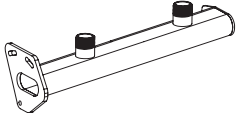
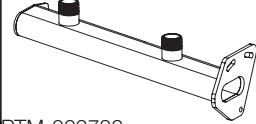
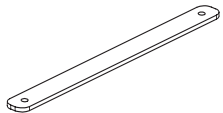
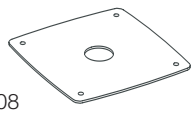

Part List			
 PTM-RM Taper mast X1	PTM-R1-2 only  DPT-R-PLATE-02 Mounting plate X1	PTM-R1-1 only  DPT-R-PLATE-01 Mounting plate X1	
 PTM-003848 PTM Wing LH X1	 PTM-003782 PTM Wing RH X1	 PTM-003863 Cover plate X2	 19008 Base seal X1
 101817 Ø16 Grommet X2	 101804 Ø23 Grommet X3	 101818 Tube cap X4	 60068 M6 Nut cover X6
 60621 M6x20 Hex Head bolt X6	 60065 M6 Washer X12	 64004 M10 Shoulder washer X4	 60060 M6 Nut X6
 610825 M8x25 CSK bolt X4	 60080 M8 Nut X4	 60085 M8 Washer X4	 65085 M5 Shoulder Washer X1
 60510 M5x10mm Pan Head X1			

FLIR M100/200 riser kit

 10039 M100-200 plate X1	 620260 M6x25mm Sockert head X6	 60068 M6 Nut cover X6	 610625 M6x25mm CSK bolt X6
 60065 M6 Washer X12	 60060 M6 Nut X12	 60702 M6 Nylon washer X12	

Parts not supplied

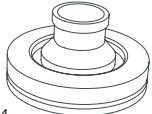
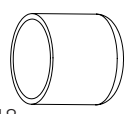
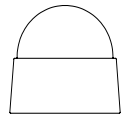
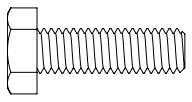
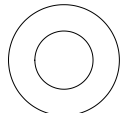
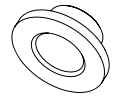
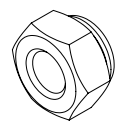
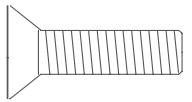
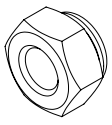
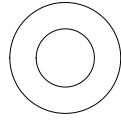
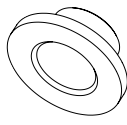
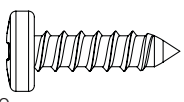
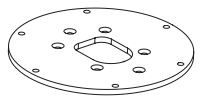
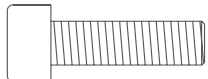
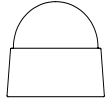
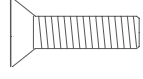
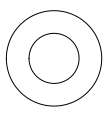
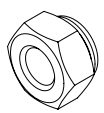
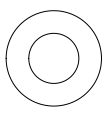
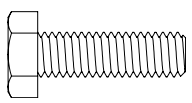
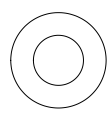
 A4 M10 Hex Head bolt suitable for install X4	 A4 M10 Washer X4
---	--





UK & International
+44 (0)1392531280
sales@scanstrut.com

For further installation
and warranty information
please visit:
www.scanstrut.com

USA
+1 860 308 1416
usasales@scanstrut.com

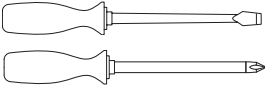
SCANSTRUT®

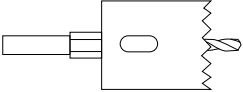
Tools Required

 <p>Pozi and flat head screwdriver</p>	 <p>Drill bit Ø10mm</p>	 <p>Hole saw suitable for cable routing</p>	 <p>Spanner 13mm x 1 10mm x 2</p>
---	--	--	--

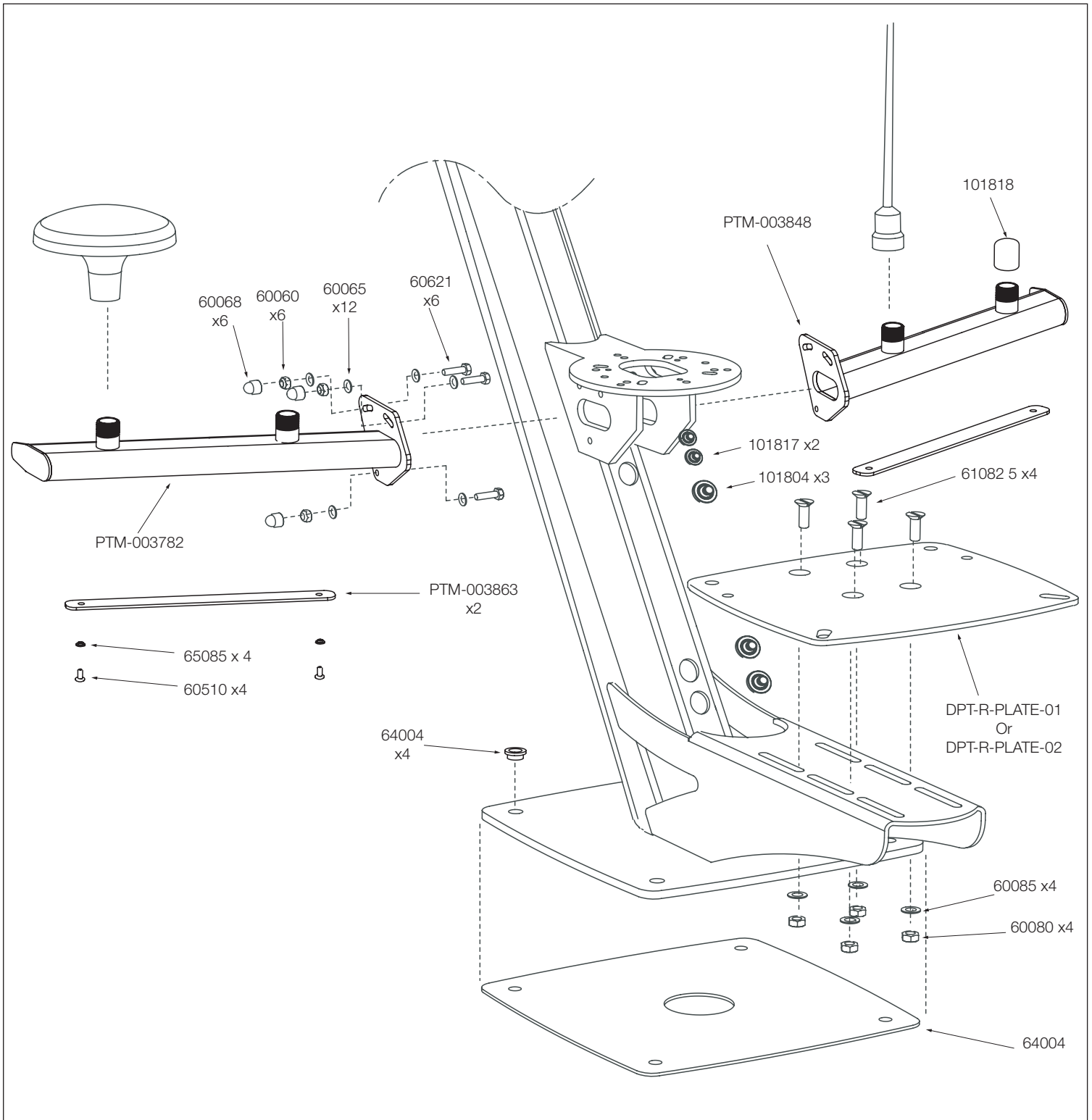

FLIR M100/200 riser kit assembly

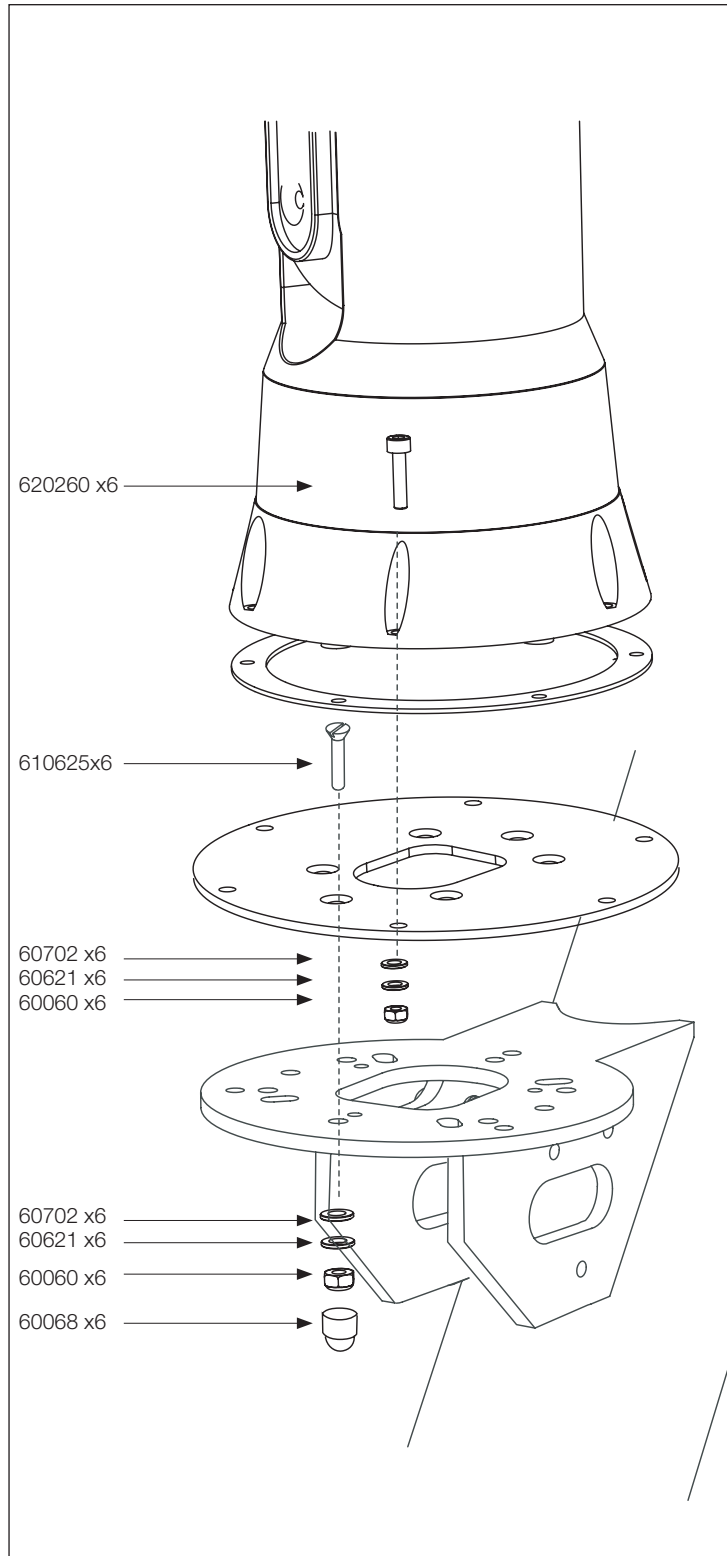

IMPORTANT

No liability is accepted for damage caused by incorrect installation.

The installation and assembly must be regularly inspected for evidence of damage or loose parts.

Product has been designed specifically for the mounting of approved marine electronics under normal boating conditions.

IMPORTANT

Scanstrut décline toute responsabilité pour les dégâts résultant d'une installation incorrecte.

L'installation et l'assemblage doivent être inspectés régulièrement afin de détecter des dégâts ou des pièces desserrées.

Ce produit a été spécifiquement conçu pour le montage d'appareils d'électronique marine approuvés dans des conditions de navigation normales.

WICHTIG

Für Schäden aufgrund unsachgemäßen Einbaus wird keine Haftung übernommen.

Der Anbau und die Baueinheit müssen regelmäßig auf Anzeichen von Schäden oder lockere Teile geprüft werden.

Dieses Produkt wurde spezifisch für die Befestigung genehmigter Elektronikgeräte für die Schifffahrt unter normalen Bootsfahrtsbedingungen entwickelt.

IMPORTANTE

Si declina qualsiasi responsabilità per danni causati da un'installazione errnea.

L'installazione e il montaggio devono essere ispezionati con regolarità per verificare la presenza di danni o di pezzi allentati.

Questo prodotto è stato studiato appositamente per il supporto di apparecchiature elettroniche navali approvate in normali condizioni di navigazione.

IMPORTANTE

No se aceptará ninguna responsabilidad por los daños causados por una instalación incorrecta.

La instalación y ensamblaje deberá inspeccionarse regularmente, comprobando cualquier evidencia de daños o piezas aflojadas.

Este producto ha sido específicamente diseñado para el montaje de equipos electrónicos marinos aprobados bajo condiciones normales de navegación.